

RMS Voltage 14.3 V

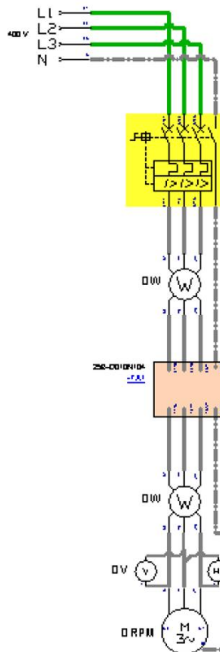

Automation Studio
PF525 Simulation

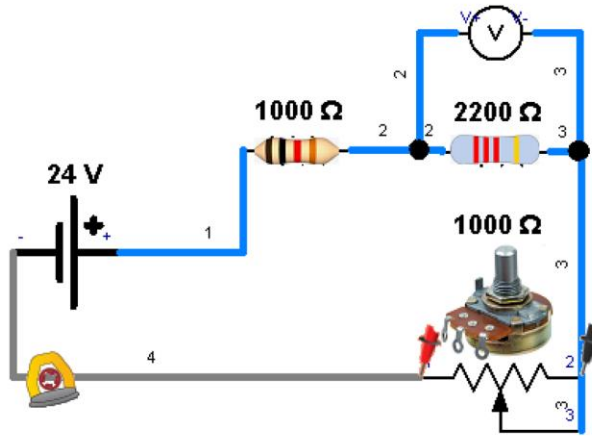