

Motor Branch Circuits Basics

IEC & NEMA Devices

Created by Tom Wylie, 3/12/17

Motor Branch Circuits

After viewing this document, the student should be able to:

1. Determine where to find the information on motor nameplates
2. Explain the difference between a C-flange and D-flange type of motor frame
3. Explain the correlation between high/low voltage wiring of a motor and the FLA
4. Explain the basic differences between a NEMA and IEC formatted electrical print
5. Explain basic differences between NEMA and IEC electrical components
6. Explain what a trip class is on a motor starter
7. Explain what a manual motor starter is
8. Interpret the numbers on the terminals of an IEC type of device
9. Compare the NEMA size starters and the IEC utilization categories
10. Explain what a 3-wire control circuit means
11. Explain the difference between a wiring diagram and a line diagram

Basic Motor Nameplate

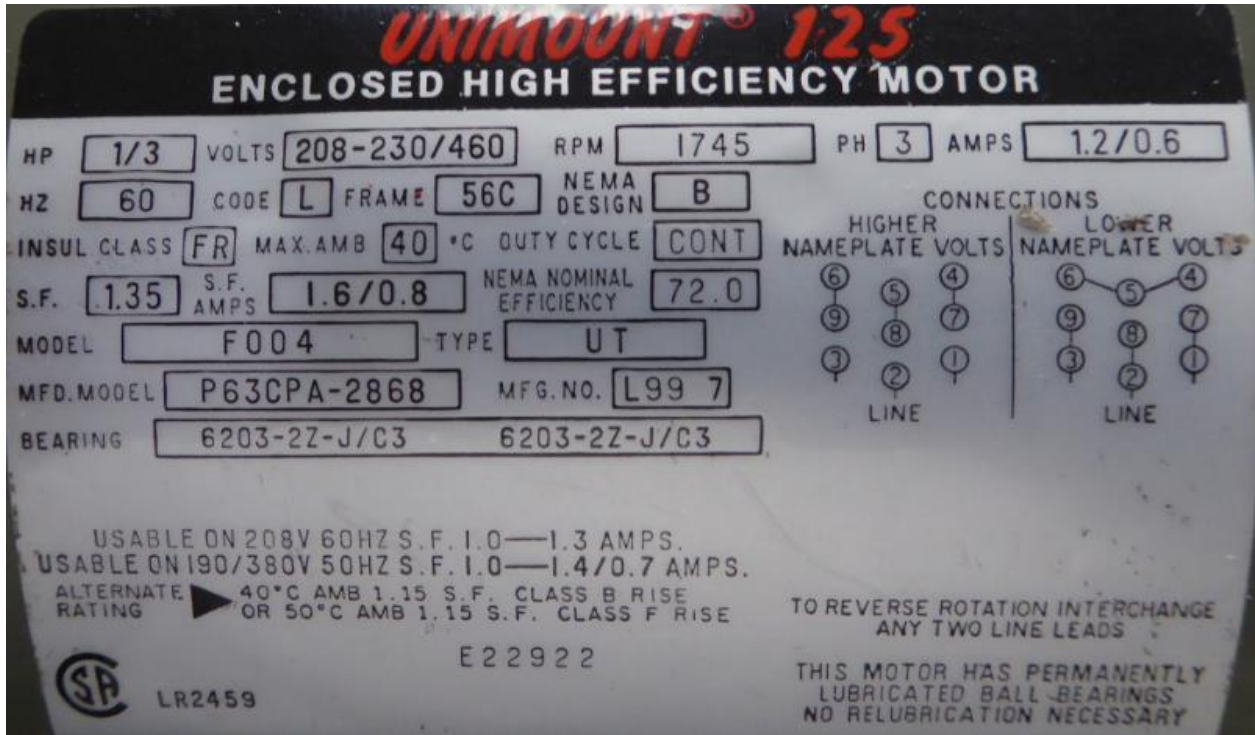

Every student going through the Motors & Controls course should be able to interpret all the information found on a motor nameplate. Your instructor will verbally test you on these during the Hands-on assessment.

To read about all the information on motor nameplate, refer to the Clemson Word or PDF files that are located in Module 2 of Sakai.

C & D Flange Motor Frames



D-Flange Motor

D-Flange motors have a plate mounted on the faceplate with straight through holes that allow the user to bolt the D-flange motor to a load. The important thing is that a bolt with a nub and washers/lock washers must be used to bolt the motor on. This is illustrated by the top graphic.

A C-Flange motor has threaded holes on the faceplate, which will allow the user to bolt the motor to a fan housing or to the load the motor is running.

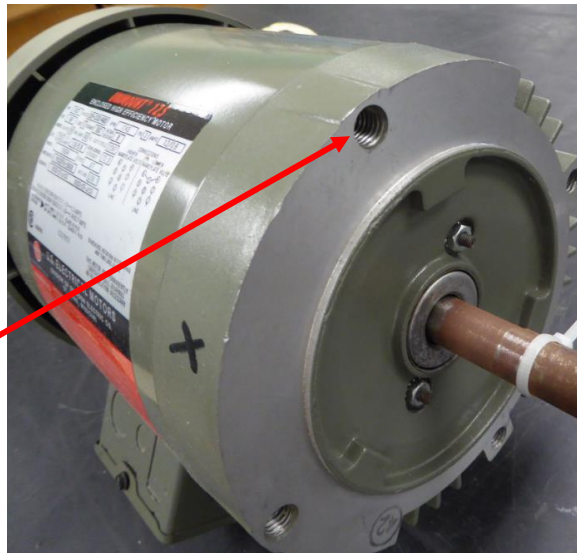

C-Flange Motor

If a motor with a frame type of 56C, this will mean the motor follows the dimensions of a 56 frame motor, but also has a C-Flange on the faceplate.

Dual Voltage Motors

Horsepower	60 Hz AC Induction Motor						
	Single Phase		Three Phase				
	115 Volt	230 Volt	200 Volt	230 Volt	380-415 Volt	460 Volt	575 Volt
1/6	4.4	2.2	~	~	~	~	~
1/4	5.8	2.9	~	~	~	~	~
1/3	7.2	3.6	~	~	~	~	~
1/2	9.8	4.9	2.5	2.2	1.3	1.1	0.9
3/4	13.8	6.9	3.7	3.2	1.8	1.6	1.3
1	16.0	8.0	4.8	4.2	2.3	2.1	1.7
1 1/2	20.0	10.0	6.9	6.0	3.3	3.0	2.4
2	24.0	12.0	7.8	6.8	4.3	3.4	2.7
3	34.0	17.0	11.0	9.6	6.1	4.8	3.9
5	56.0	28.0	17.5	15.2	9.7	7.6	6.1
7 1/2	80.0	40.0	25.0	22.0	14.0	11.0	9.0
10	100	50.0	32.0	28.0	18.0	14.0	11.0

Most three phase motors sold today are dual-voltage, which means they will run on low voltage or high voltage (208-230/460). These are typically nine lead motors, and will have the wiring diagram right on the nameplate.

One important aspect is that if the motor is wired for high voltage (which is usually the case), the motor pull half the current than it would, wired for low voltage. Whether the motor is wired for low or high voltage does not affect the operation of the motor.

The advantage of wiring for the higher voltage is that the installation will not need as large of wire for the power feed. This is especially noticeable as you get above 10HP.

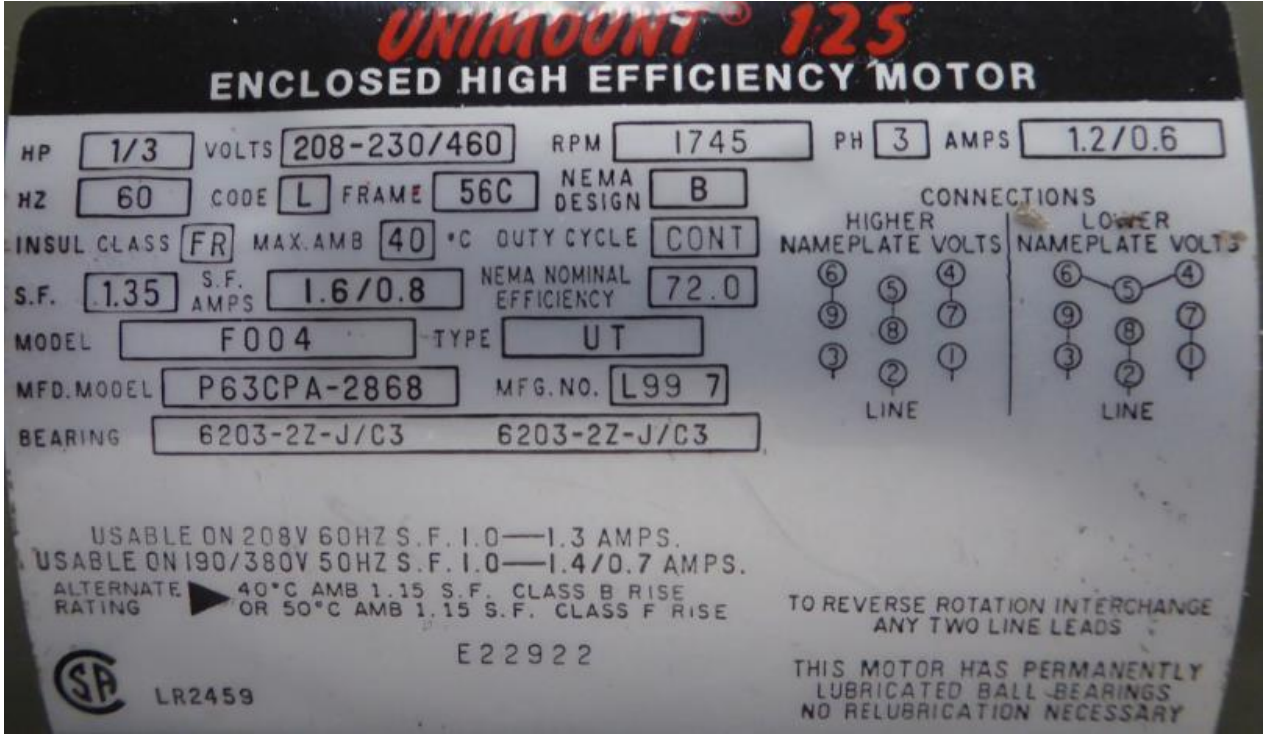

NEMA & IEC Formats on Electrical Prints

NEMA

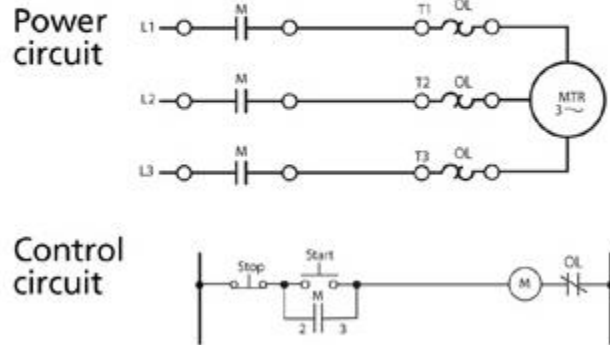

IEC

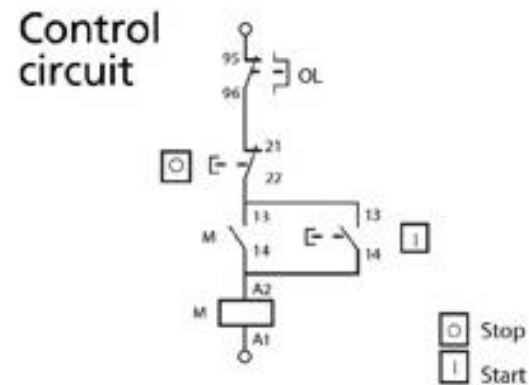
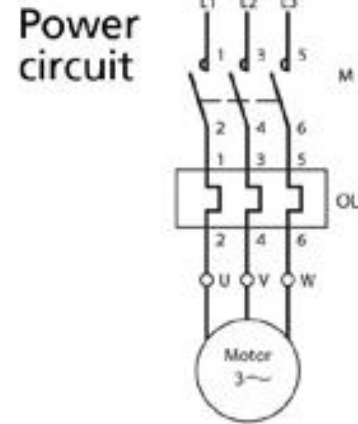

One of the most critical tasks when troubleshooting an electrical circuit is the interpretation of how a circuit is connected. To do this the user must be able to read an electrical print, both the symbols and wiring configurations.

Many textbooks teach only NEMA type of prints, but the number of IEC prints are growing.

If a machine is built in Germany or Italy (both very common), the prints will be in an IEC format. A company typically has to pay extra to have the prints formatted for NEMA. To minimize costs, the machine will come with IEC prints.

A circuit could consist of all NEMA parts, but have the prints in an IEC format, or vice versa. The type of electrical standard components and the format of the electrical print is two completely different things. These diagrams give you an idea of how different these two formats are. You will need to memorize the symbols for both in most cases.

A Start/Stop circuit in an IEC format

Push Button		Basic Contacts		SPDT	Coil	Fuse
Momentary N.O	Momentary SPDT	Normally Closed	Normally Open			

This control circuit will drill down a little farther on the symbols used in an IEC control circuit. The chart at the top will have the basic control symbols for IEC formatted prints.

As soon as a user sees the coil marked as A1 & A2, and the overload marked as 95 & 96, they should know they are working with an IEC device. Realize that the IEC devices can be used in a NEMA formatted print.

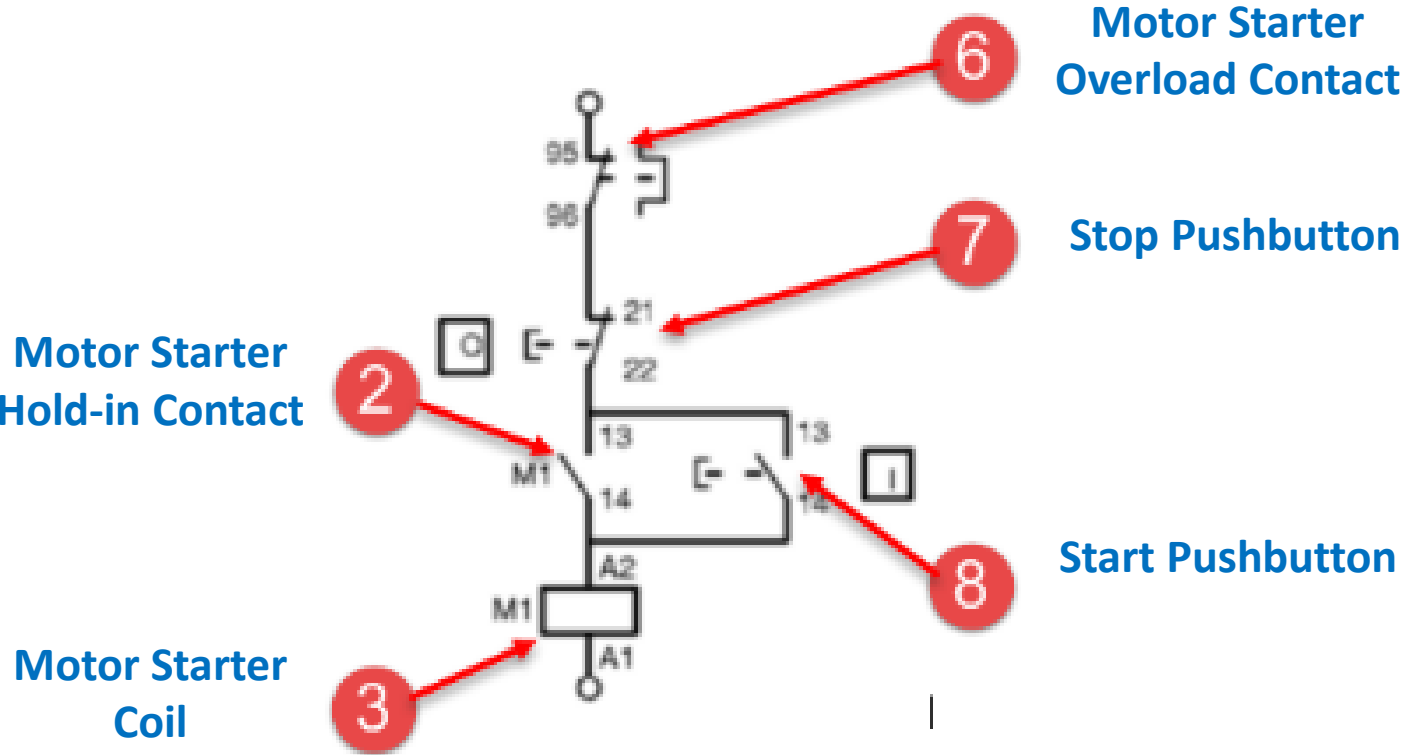

****Important**** - Memorize these basic control symbols. Your instructor will quiz you on these during the HOA assessment.

For more information on NEMA versus IEC type for format for electrical prints: see the PDF handout from Eaton corporation named: "Comparing IEC and NEMA symbols_Eaton.pdf", found in Module 2

The Power Circuit of an IEC Motor Starter

Power circuit

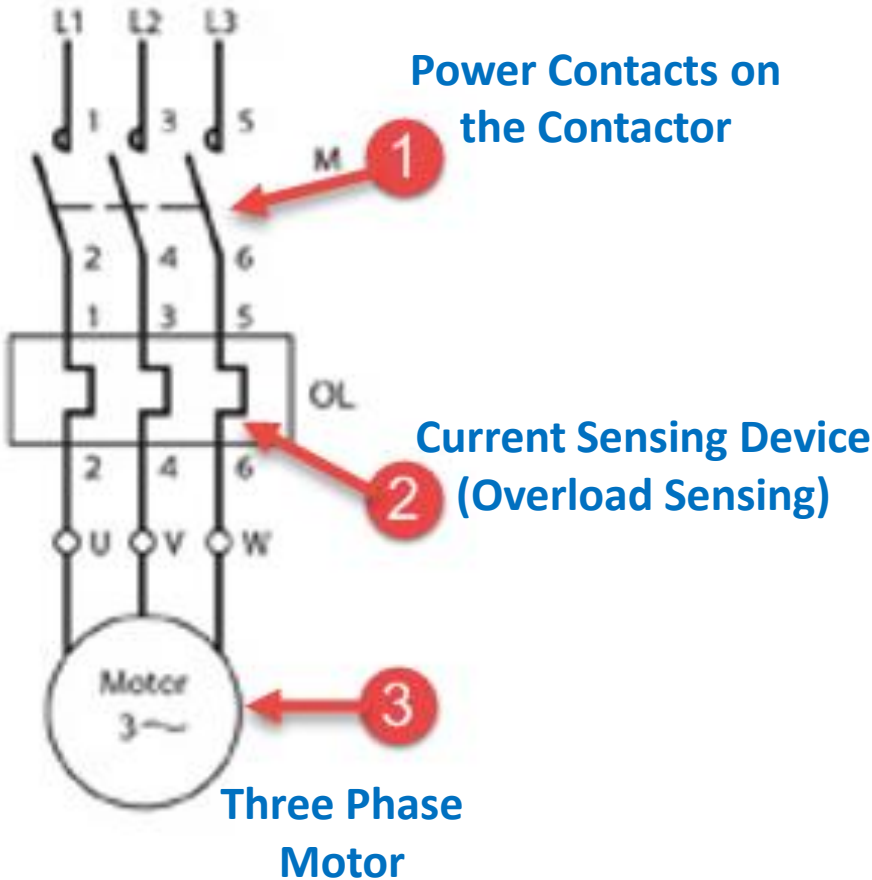

This is the power circuit for the power circuit of a motor branch circuit, based on an IEC formatted print (minus the 3 phase fuse block that is not shown).

Notice that L1, L2 & L3 is not used, nor is T1, T2 & T3 on the contactor or overload block. Most IEC devices use 1,2,3,4,5&6 for the power contacts, and U, V & W for the output (instead of T1, T2 & T3).

The Power & Control circuit in a NEMA format

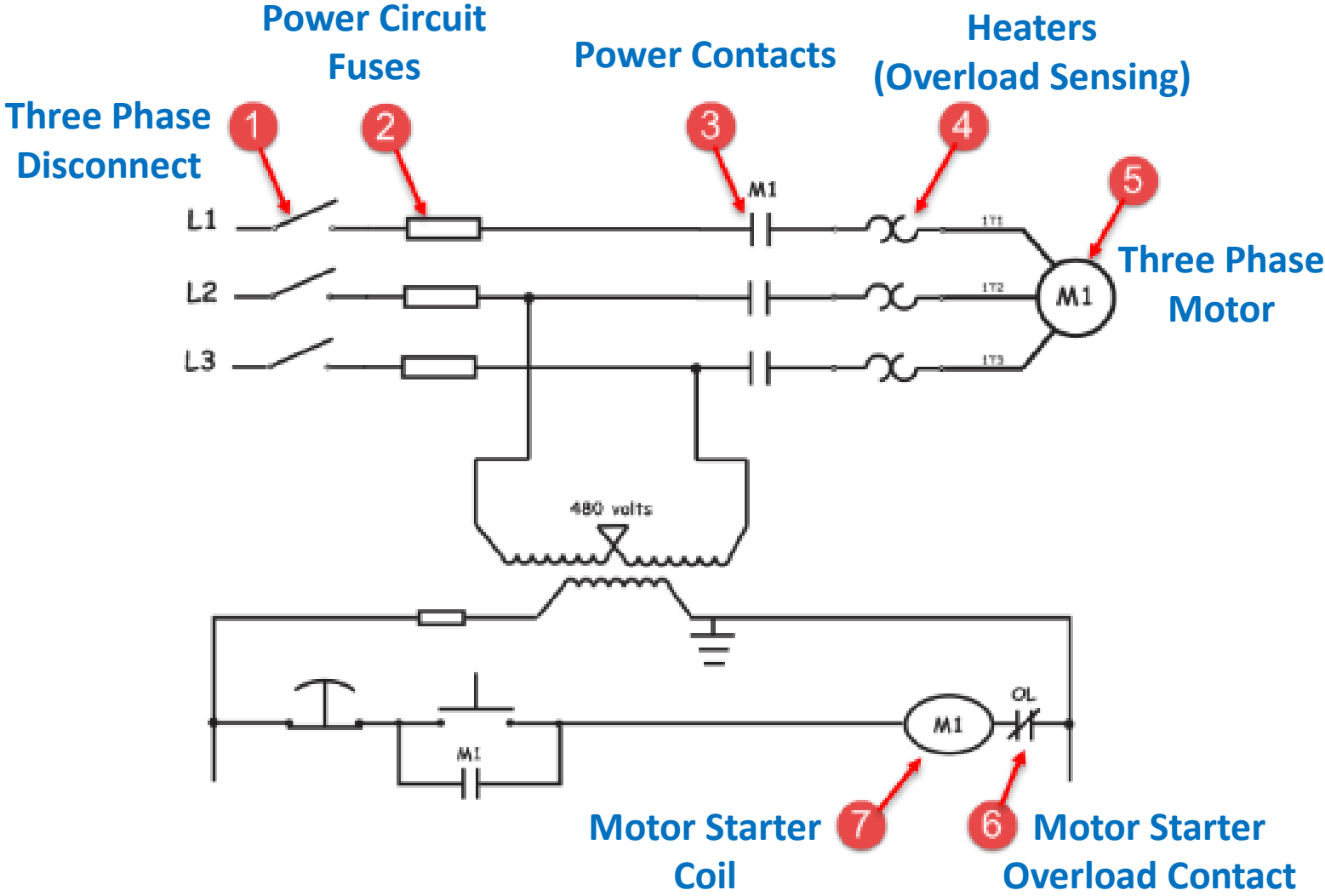

This is the power and control circuit for a motor branch circuit that is formatted for NEMA on the electrical print. Memorize all of these symbols for the HOA your instructor will be performing.

One thing to note is that there is a fuse on the secondary side of the transformer that feeds the control circuit. This fuse should protect the circuit and the transformer. If this is 120V secondary, the fuse should be sized for the maximum amount of current that the transformer can handle, per discussed in Module 1.

For more information on NEMA versus IEC type for format for electrical prints: see the PDF handout from Eaton corporation named: "Comparing IEC and NEMA symbols_Eaton.pdf", found in Module 2

IEC versus NEMA Power & Control Devices

IEC versus NEMA

IEC is usually less expensive.	NEMA can better withstand overloads.
IEC takes up significantly less space.	NEMA requires less precision in design.
IEC starter includes single-phase detection.	NEMA is better for applications with load uncertainties.
IEC starter provides quicker detection of overload conditions.	NEMA can more easily withstand short circuits.
IEC is finger safe.	NEMA is more rugged and can better withstand abuse.

This chart shows some basic difference between NEMA and IEC devices. The NEMA devices are much more robust, but for anything less than 100HP rating, NEMA is double the size and double the price of an IEC device.

A NEMA installation requires minimal engineering for a motor branch circuit installation. An IEC installation requires quite a bit of engineering. IEC devices are rated in current and also has specifications on the duty cycle (not continuous). NEMA on the other hand is pretty much constant duty.

NEMA has been around for many years, but now IEC is overtaking NEMA as far as the number of installation. A safe bet is that any industrial technician will need to know how to work on both.

Another term the user may run into is finger safe. The diagram to the right shows this concept.



IP2X Finger safe is an IEC rating. Finger safe means the screws are recessed and the opening is only 12.5 mm, so most fingers cannot fit into the opening

IEC versus NEMA Starters

This illustration shows a NEMA motor starter on the left, and an IEC motor starter on the right.

Both of these devices are rated at 27 amps. As you can see the NEMA is quite larger and is also more expensive. It is durable, will last a long time, and is considered of higher quality when speaking with people that work in the maintenance field.

The IEC is smaller, less expensive, but also has some features that is lacking in the NEMA. One of the most obvious is that the overload trip is adjustable, which has its advantages if a motor needs replacing and the FLA is a little more or less. Whereas the NEMA has heaters that are set and not adjustable.

Another nice feature of IEC is that phase loss detection is standard. So if a power fuse blows, the starter senses the phase loss and trips the overload.



IEC versus NEMA Starters cont.



Another advantage of IEC motor starters is that the overload relays can be purchased with multiple Trip Class settings (this is standard on most overload relays).

The Trip Class refers to the amount of time that an overload condition exists before the overload relay trips out and changes the state of the overload contact.

Most NEMA starters have a Trip Class of 20, where the IEC as shown is adjustable with DIP (Dual Inline Package) switches that will Trip Classes of 10, 15, 20 and 30.

Basically a Trip Class of 10 means that if the motor is pulling 6 times the FLA of the motor in an overload, the starter will trip out in 10 seconds.

Realize that if the overload is twice the FLA, the Trip Class of 10 will take longer than 10 seconds to trip, but will trip faster than a Trip Class of 20.

This feature on an IEC starter, simply protects the motor better than a NEMA starter does.

These are DIP switches that are found on the side of many IEC overload relays that will allow the user to set the Trip Class



Overload Trip Class

Trip Class 10

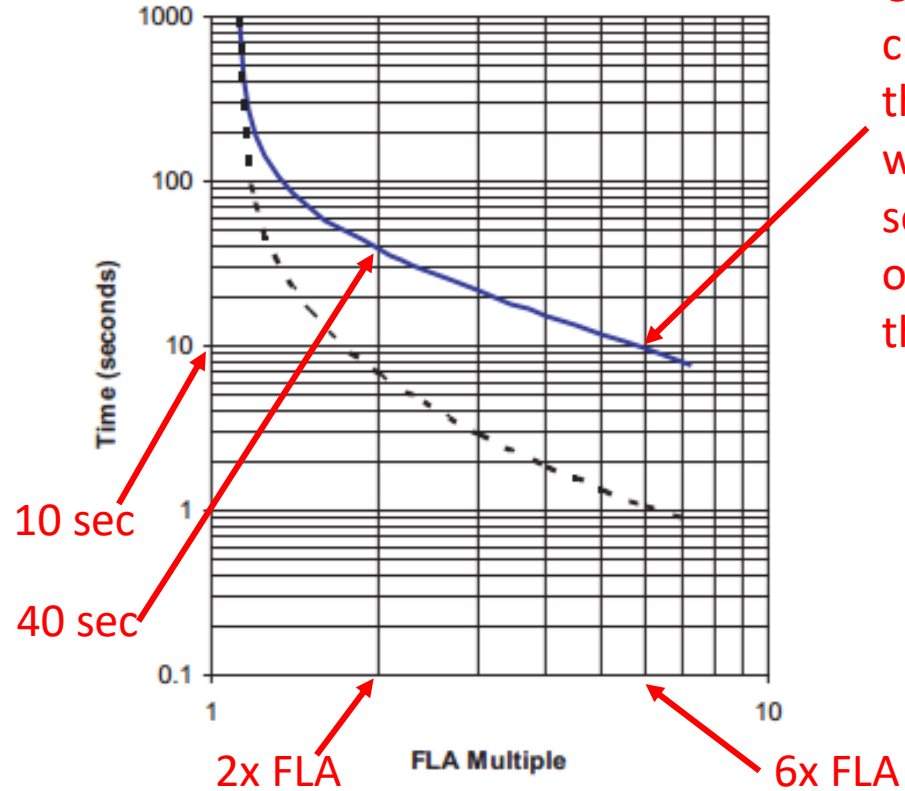

This is a Time versus FLA chart from a vendor cut-sheet on an IEC overload relay. It would be similar for a NEMA overload relay.

Notice that the curve, time or FLA is not linear. This is why the user needs to be able to read this type of diagram.

At 6 times the FLA, the overload trips in 10 seconds.

At 2 times the FLA, the overload will trip in 40 seconds.

At 4 times the FLA, the overload will trip in approximately 17 seconds.

IEC Motor Starter Overload Relay

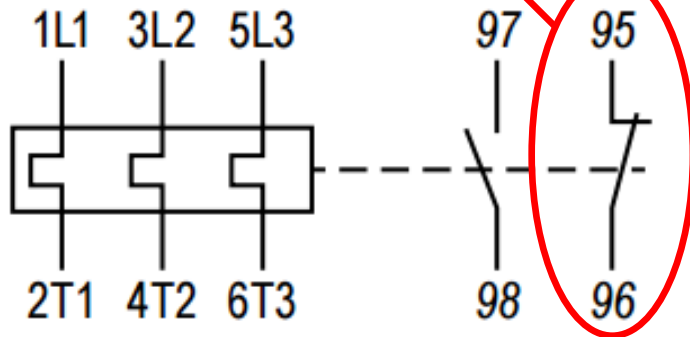

The overload relay used on the IEC motor starters on the NSCC wiring boards are the AB E1 Plus. These have both a N.O. and N.C. overload contacts as shown in this illustration.

The unit is purchased as a 1-5 amp unit, and is adjustable to whatever the FLA is on the motor nameplate.

The unit also has a test button to allow the user to trip the overload manually, and a reset button to reset it.

There are also DIP switches on the side of the overload unit that will allow the user to choose the Trip Class (how fast the unit will trip during an overload), and a switch to determine if the overload should be manually reset, or automatically reset after an overload.

IEC Manual Motor Starter



This illustration shows an IEC Manual Motor Starter. The unit will shut off the motor with a manual switch, but will also protect the motor by sensing an overload, thus tripping the switch on the motor starter. The overload amount is adjustable, in this case between 18-25 amps.

The diagram in the lower right will show what a manual motor starter looks like on an electrical print.

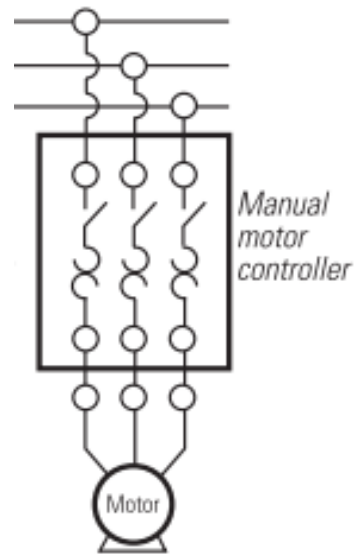

IEC Contactor



Notice on this IEC contactor, that the print may have the designations of 1, 3 & 5 instead of L1, L2 & L3 for the power connections at the top of the contactor.

At the bottom of the contactor (output), terminals are also designated as 2, 4 & 6, instead of T1, T2 & T3.

The diagram at the bottom right is a diagram from an IEC contactor cut sheet. Notice the IEC symbols. Also notice that the diagram has only 1 auxiliary contact, but the actual contactor has a Normally Open contact (terminals 13 & 14), and a Normally Closed contact (terminals 21 & 22)

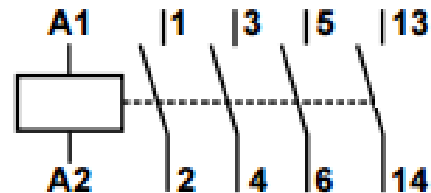

What do the numbers mean on an IEC relay?

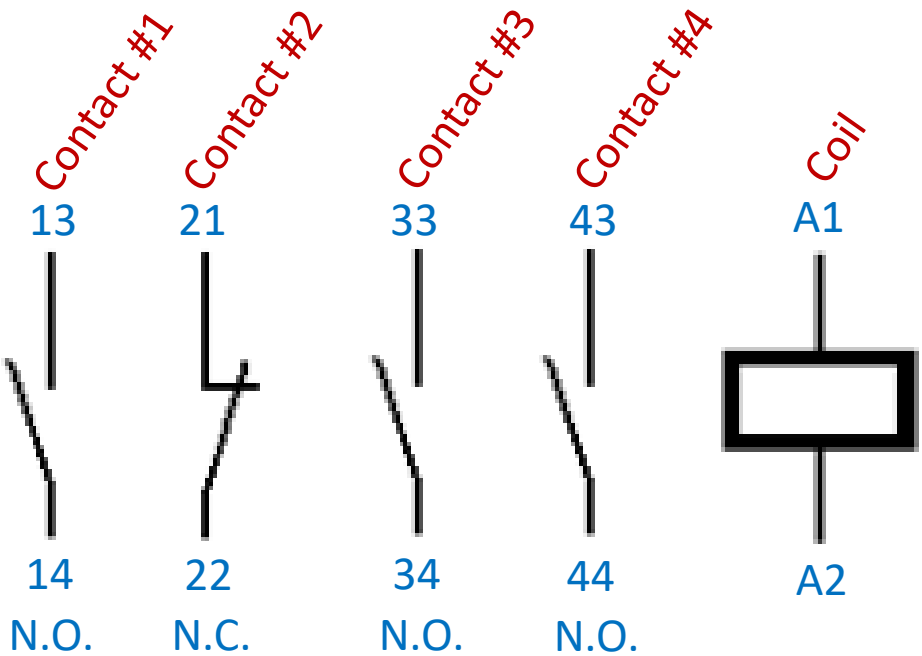

Most text books and manufacturer cut-sheets do not explain anything about the numbering of the contacts on IEC devices. These are not random numbers. The first digit simply means the contact number on the device. The second number defines N.O. (3 & 4), or N.C. (1 & 2), as shown in the illustration. A1 & A2 is always the terminal identifiers for a coil, on an IEC device.

- The first digit of each number is the contact number
- The second digit is the type of contact
- If the second digit is a 3 & 4, the contact is normally open
- If the second digit is a 1 & 2, the contact is normally closed
- A1 & A2 is always the coil



Sizing NEMA and IEC Starters

NEMA Size	Continuous Amp Rating	HP 230 VAC	HP 460 VAC
00	9	1	2
0	18	3	5
1	27	5	10
2	45	15	25
3	90	30	50
4	135	50	100
5	270	100	200
6	540	200	400
7	810	300	600
8	1215	450	900
9	2250	800	1600

NEMA and IEC approach things quite differently. As a technician, you must know both of these types of systems. A NEMA starter is sized from 00-9 (for contactors and starters), as shown in the standard NEMA chart (upper illustration).

IEC Utilization Categories			
Voltage	Category	Typical Applications	IEC Product Standard 3
A.C.	AC-1	Non inductive or slightly inductive loads, example: resistive furnaces, Heaters	947-4
	AC-2	Slip-ring motors: switching off	
	AC-3	Squirrel-cage motors: starting, switches off motors during running time <i>Most typical industrial application for motors</i>	
	AC-4	Squirrel-cage motors: starting, plugging (1), inching (2)	
	AC-5a	Switching of electric discharge lamps	
	AC-5b	Switching of incandescent lamps	
	AC-6a	Switching of transformers	
	AC-6b	Switching of capacitor banks	
	AC-7a	Slightly inductive loads in household appliances: examples: mixers, blenders	
	AC-7b	Motor-loads for household appliances: examples: fans, central vacuum	
	AC-8a	Hermetic refrigerant compressor motor control with manual resetting overloads	947-5
	AC-8b	Hermetic refrigerant compressor motor control with automatic resetting overloads	
	AC-12	Control of resistive loads and solid state loads with opto-coupler isolation	
	AC-13	Control of solid state loads with transformer isolation	
	AC-14	Control of small electromagnetic loads	947-3
AC-15	Control of A.C. electromagnetic loads		
AC-20	Connecting and disconnecting under no-load conditions		
AC-21	Switching of resistive loads, including moderate loads		
AC-22	Switching of mixed resistive and inductive loads, including moderate overloads		
AC-23	Switching of motor loads or other highly inductive loads	947-2	
A.C. and D.C.	A		Protection of circuits, with no rated short-time withstand current
	B	Protection of circuits, with a rated short-time withstand current	

IEC does not specify a size for a starter, but instead they use Utilization Categories. This is basically the type of load that the IEC device is sized for. As you can see an AC-1 is a resistive load (heating elements), and an AC-3 is for squirrel cage motor. AC-4 is for inching and plugging AC motors.

On this IEC motor starter contactor, it has sizing based on AC-1 or AC-3 type of loads. An AC-1 application is good for 32 amps. AC-3 is good for a 3kW motor at 240V, 3 phase

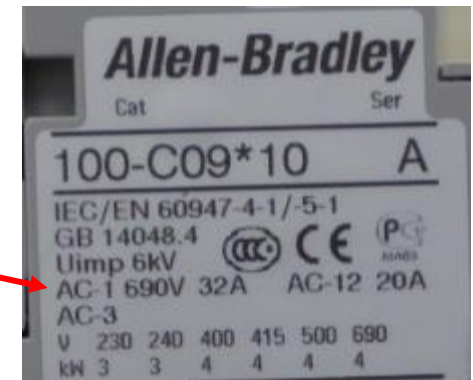

Wiring Diagram versus a Line Diagram

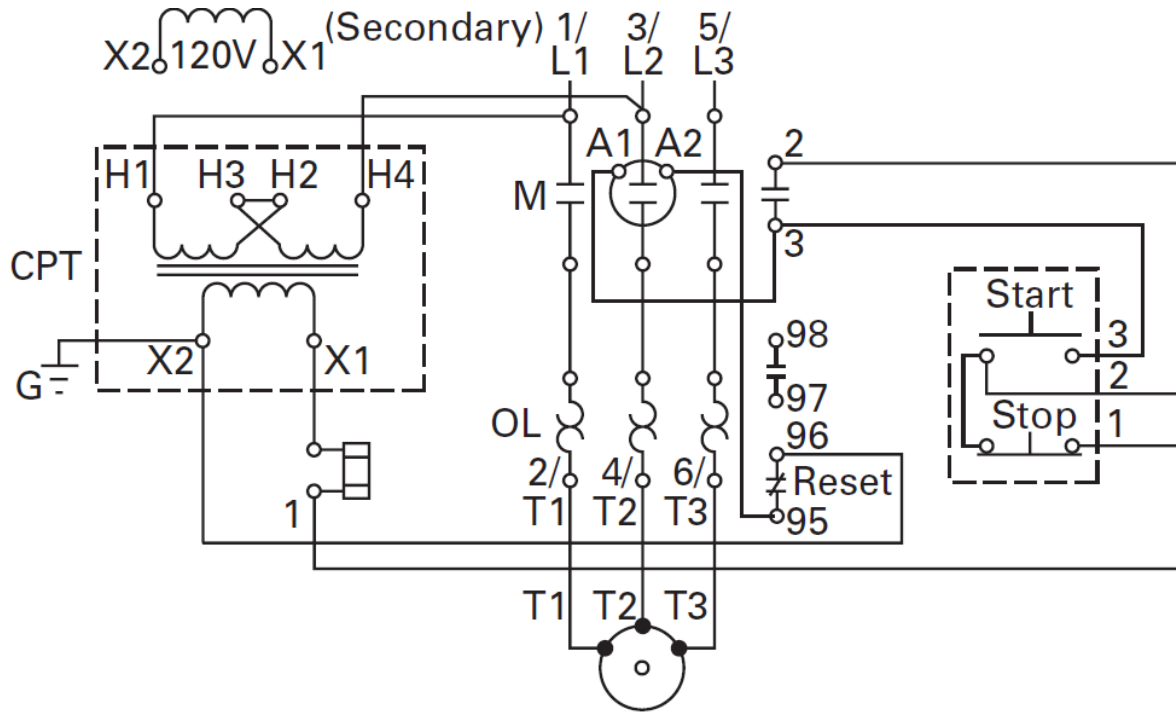

The upper diagram is called a wiring diagram and is shown in the format that is typically found on a manufacturer cut-sheet. This is a very confusing diagram.

The lower diagram is called a line diagram and is in the format that the user will typically find on an electrical print.

The term “CPT” stands for Control Power Transformer. Notice that the X2 wire is grounded, which makes it a neutral, which means it cannot be fused or broken with a switch.

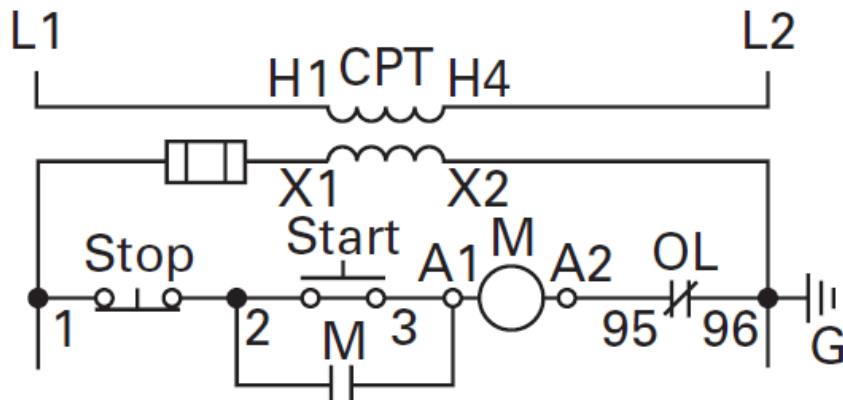

3-Wire Control (start/stop station)

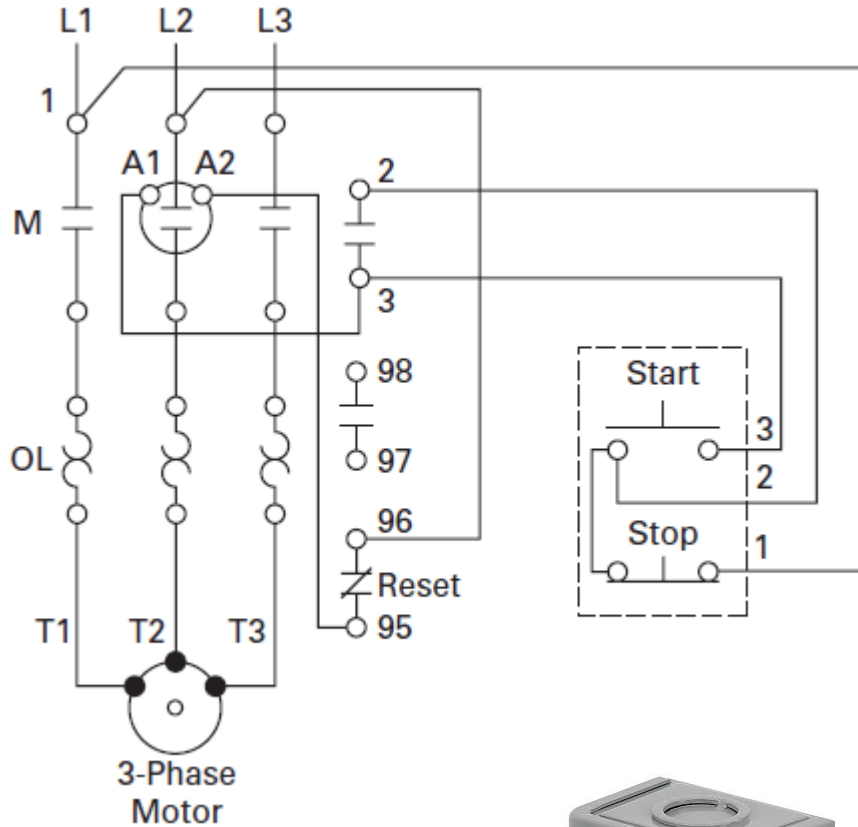

3-Wire Control

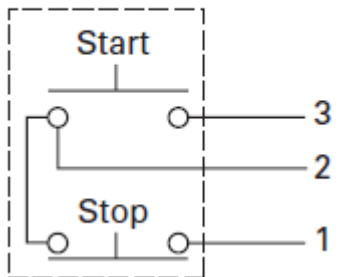

Many people get confused with term “three wire control”, but it is a term that is used all the time in motor control circuits and variable frequency drive circuits.

The term “three wire control” is an old term that was created since there would be 3 wires that would be run to a start/stop pushbutton station.

Some people term these as start/stop circuits.

In a typical three wire circuit, the hot wire is run to one side of the stop pushbutton, then a jumper between the other side of the stop button to one side of the start button. A hold-in contact will be wired in parallel with the start pushbutton.

Practice Question #1

- In this IEC control circuit, what is the device that has the number “6” attached to it?
 - a. The Stop pushbutton
 - b. The Start pushbutton
 - c. An auxiliary contact on the contactor
 - d. An overload contact
 - e. The contactor coil

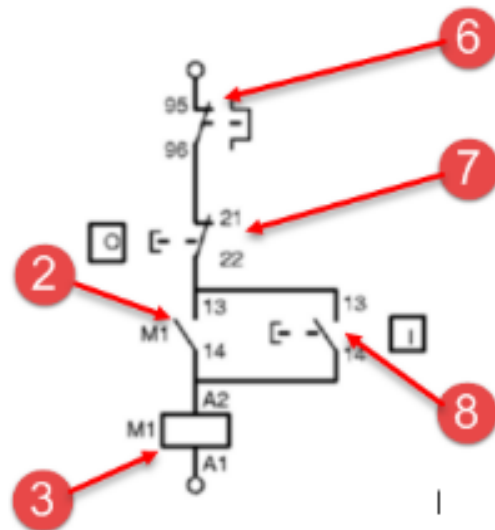

The Answer to Practice Question #1

- In this IEC control circuit, what is the device that has the number “6” attached to it?
 - a. The Stop pushbutton
 - b. The Start pushbutton
 - c. An auxiliary contact on the contactor
 - d. **An overload contact**
 - e. The contactor coil

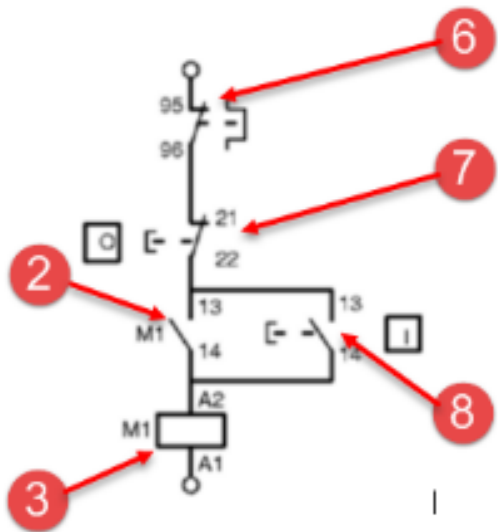

Explanation: This device is the overload contact. A number 95 & 96 are the standard terminal markings for the overload contact on an IEC motor starter. 7 is the stop button, 2 is the hold-in contact, 8 is the start button, and 3 is the coil.

Practice Question #2

- An IEC relay has two wire terminals marked as 13 & 14. Is this a normally open, or normally closed contact?
 - a. Normally Open
 - b. Normally Closed

Answer to Practice Question #2

- An IEC relay has two wire terminals marked as 13 & 14. Is this a normally open, or normally closed contact?
 - a. **Normally Open**
 - b. Normally Closed

Explanation: On an IEC relay or Contactor, the second digit of a terminal marking designates the type of contact. A “1 & 2” for the second digits is a normally closed contact. A “3 & 4” for the second digit is a normally open contact. So a 13 & 14 means that it is the first auxiliary contact on the relay or contactor, and the 3 7 4 mean normally open.

Practice Question #3

- Which of the following trip classes on an IEC or NEMA motor starter will trip the overload the quickest?
 - a. Trip class 10
 - b. Trip class 15
 - c. Trip class 20
 - d. Trip class 30

Answer to Practice Question #3

- Which of the following trip classes on an IEC or NEMA motor starter will trip the overload the quickest?
 - a. **Trip class 10**
 - b. Trip class 15
 - c. Trip class 20
 - d. Trip class 30

Explanation: The definition of a trip class is how long it takes an overload relay to trip once the overload reaches 6 times the FLA on the nameplate. A class 10 will trip in 10 seconds, which will be the fastest.

Practice Question #4

- In the following IEC power circuit, what is the device that is marked with a “1”?
 - a. 3 phase disconnect
 - b. Power contacts on the contactor
 - c. Overcurrent sensing devices
 - d. None of the above

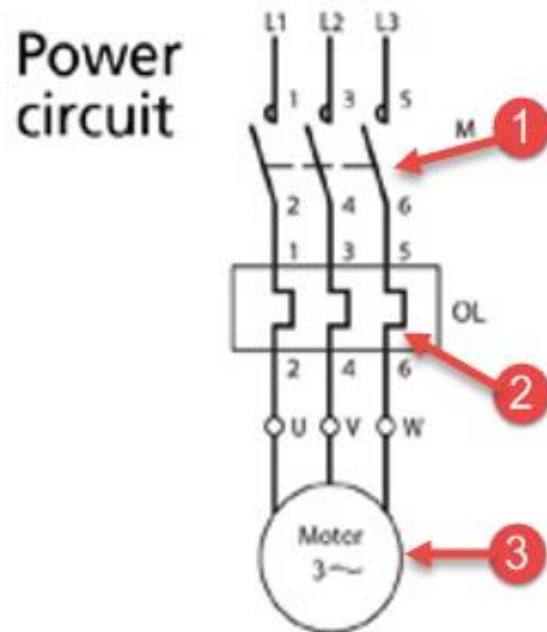

Answer to Practice Question #4

- In the following IEC power circuit, what is the device that is marked with a “1”?
 - a. 3 phase disconnect
 - b. **Power contacts on the contactor**
 - c. Overcurrent sensing devices
 - d. None of the above

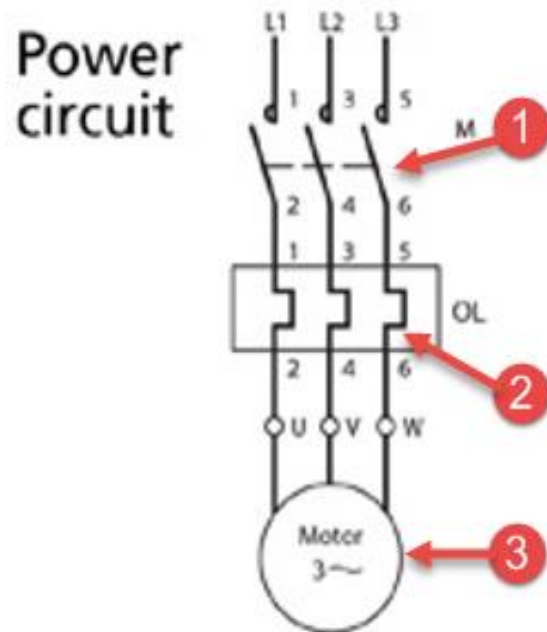

Explanation: A dead give away is the “M” beside the contacts. These are the power contacts. It does look like a disconnect.

Notice the markings of 1,2,3,4,5 & 6.

This Concludes this Instructional Document

DOL DISCLAIMER:

This product was funded by a grant awarded by the U.S. Department of Labor's Employment and Training Administration. The product was created by the grantee and does not necessarily reflect the official position of the U.S. Department of Labor. The Department of Labor makes no guarantees, warranties, or assurances of any kind, express or implied, with respect to such information, including any information on linked sites and including, but not limited to, accuracy of the information or its completeness, timeliness, usefulness, adequacy, continued availability, or ownership.



This work is licensed under a [Creative Commons Attribution 4.0 International License](https://creativecommons.org/licenses/by/4.0/).