

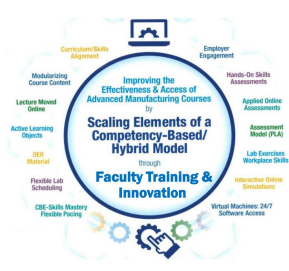

Remote Student Learning using Virtual Machines & Simulations

Presented by:

Tom Wylie, Northwest State CC
Archbold, OH



This PowerPoint/PDF document shows multiple online simulations that the Project PI has created, and implemented into various technical courses, and teach faculty at other college how to do the same. The PLC virtual simulators are built in C#, or can be created in a PLC HMI software, such as Factory Talk View Studio. There are numerous simulations built with Automation Studio, a simulation software created by Famic Corporation from Quebec. This is a very common software used at 2 and 4 year colleges nationally.

If you have an interest in any of these simulations, please reach out to the Project PI, Tom Wylie, at twylie@northweststate.edu

The purpose of the Scaling Elements (NSF) grant is to assist/mentor Faculty to improve their courses by implementing/enhancing elements used in successful competency based instructional models (listed outside the circle in the graphic below).





Purpose of a Virtual Machine (Computer)?

- Give students 24/7 access to Proprietary Software
- Give students 24/7 access to Online Simulations

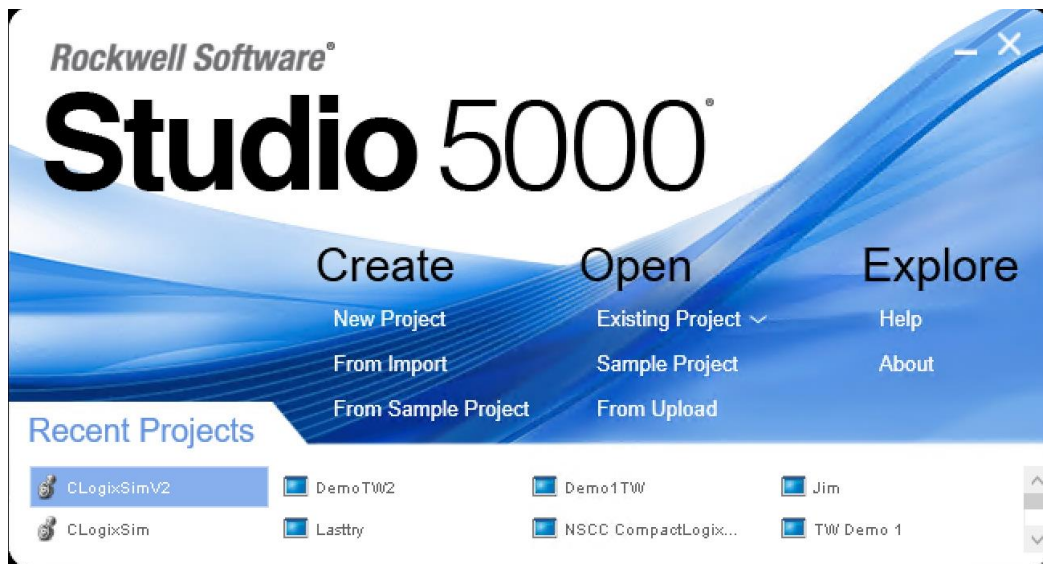

PLC Lab on campus



The content of the virtual machine will have all of the same functionality as being in the PLC Lab

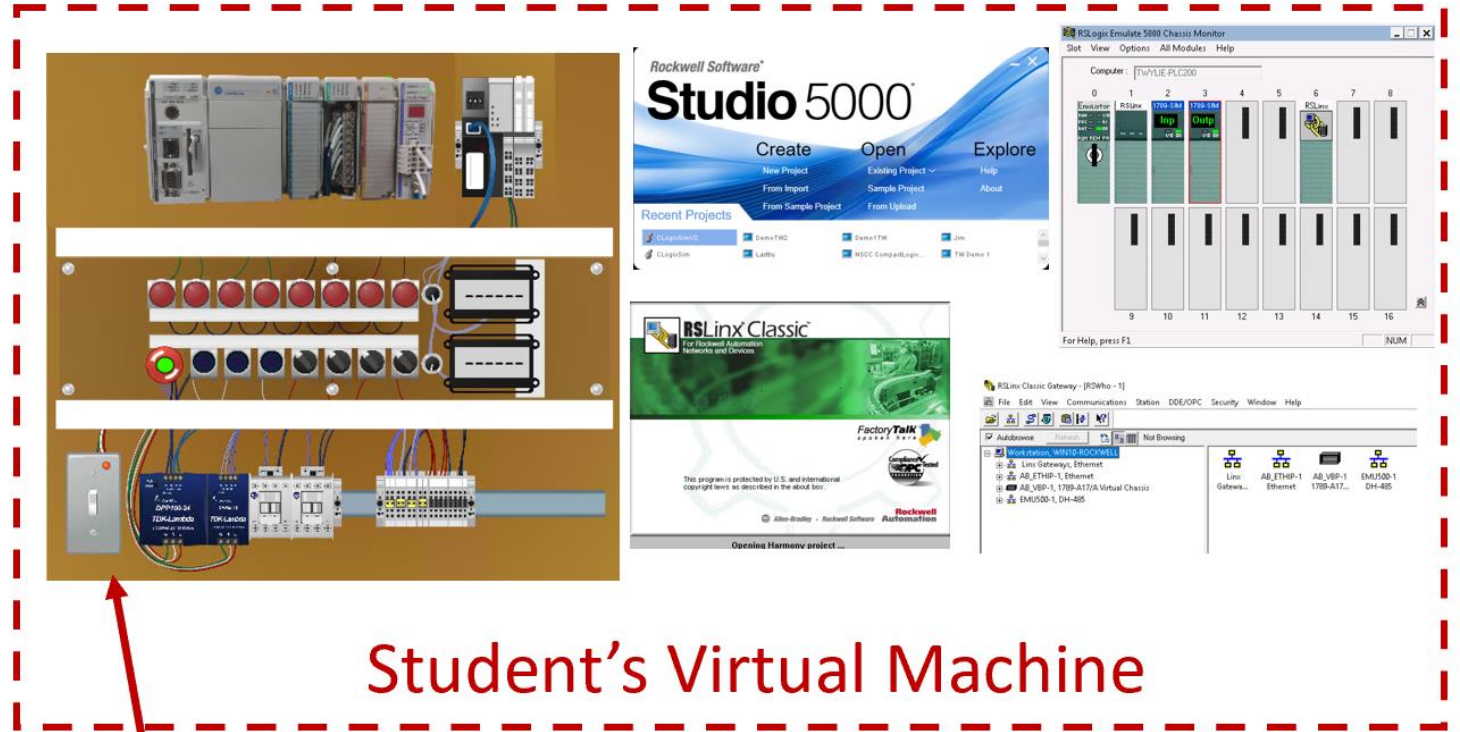

Student's Virtual Machine

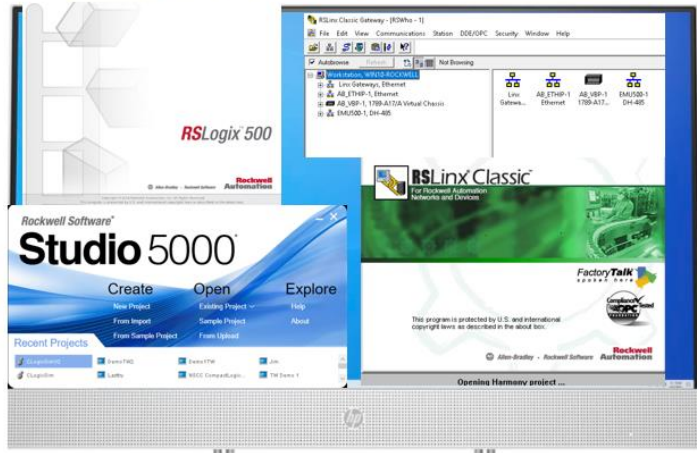

Computer in PLC Lab



Virtual PLC Simulator

College Firewall

Internet

Student Computer at Home



Wireless Router (Home)





The Virtual PLC Simulator created to replicate the functionality of the SLC-500 training unit.

Hardware Simulator

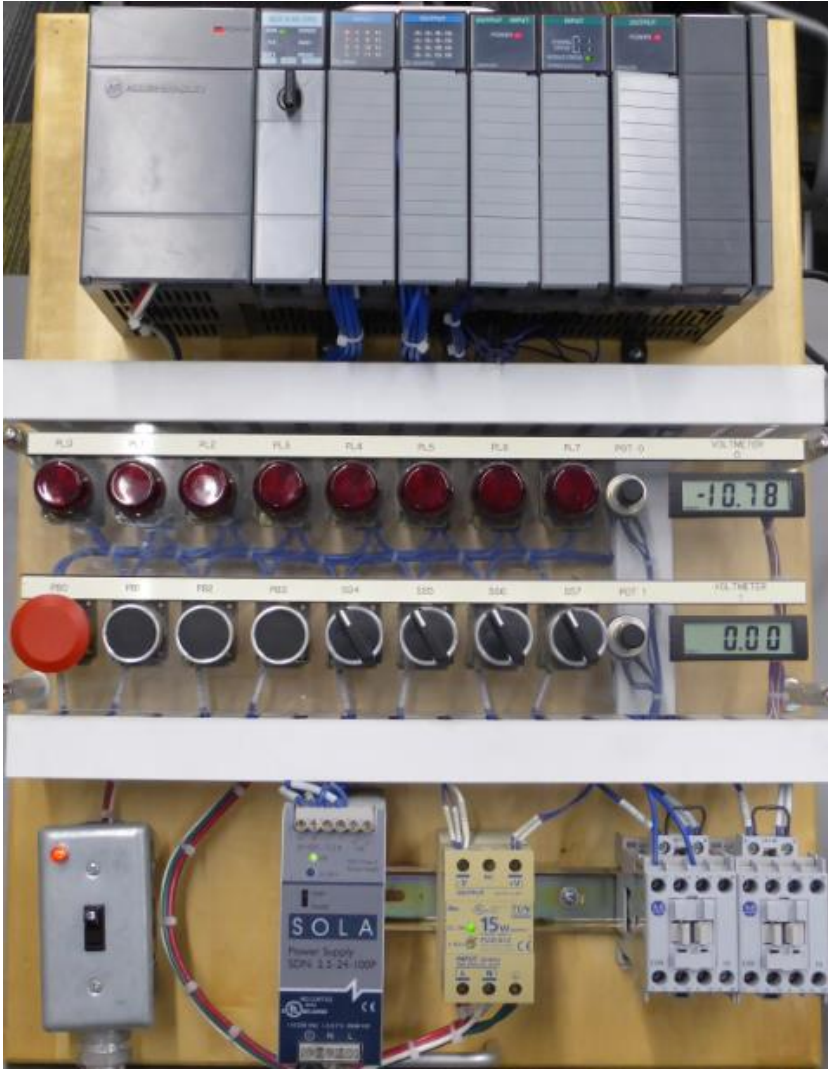

Virtual Simulator

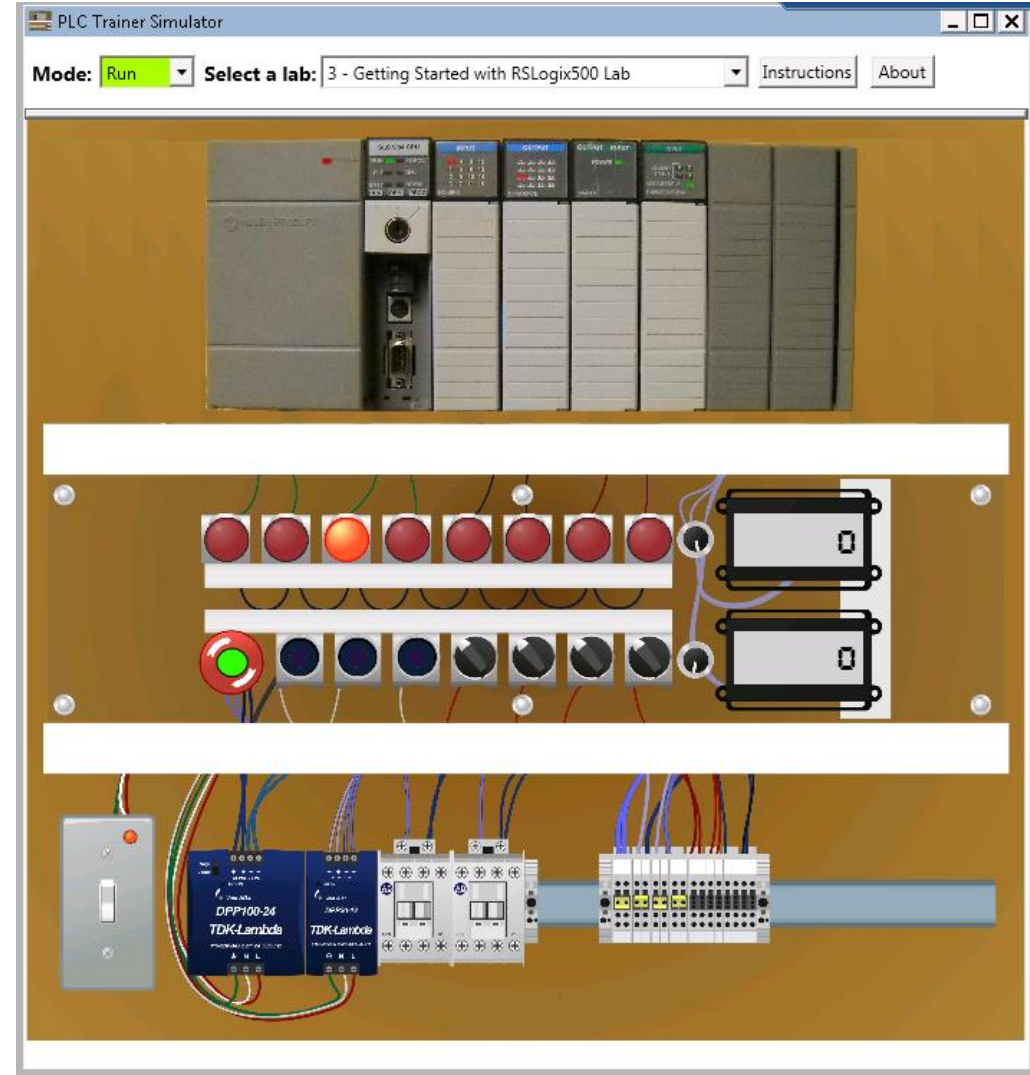



The Virtual PLC Simulator created to replicate the functionality of the CompactLogix training unit.

Hardware Simulator



Virtual Simulator

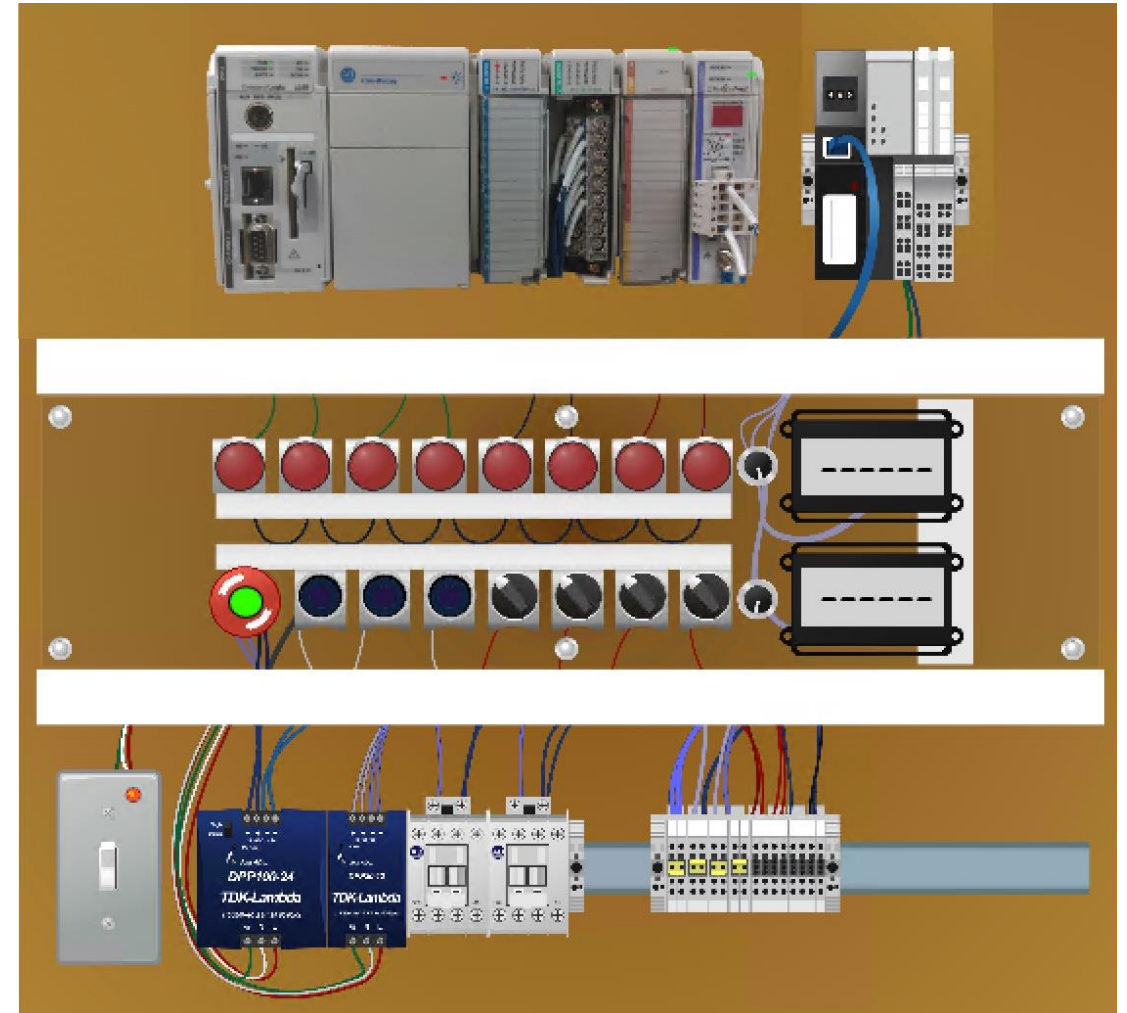



The Virtual PLC Simulator, enhanced with Factory Talk View Studio, which will allow the unit to communicate with the Studio 5000 Emulator with FactoryTalk Linx. This will allow students to run their programs on the simulator that were created in Studio 5000

Virtual Simulator

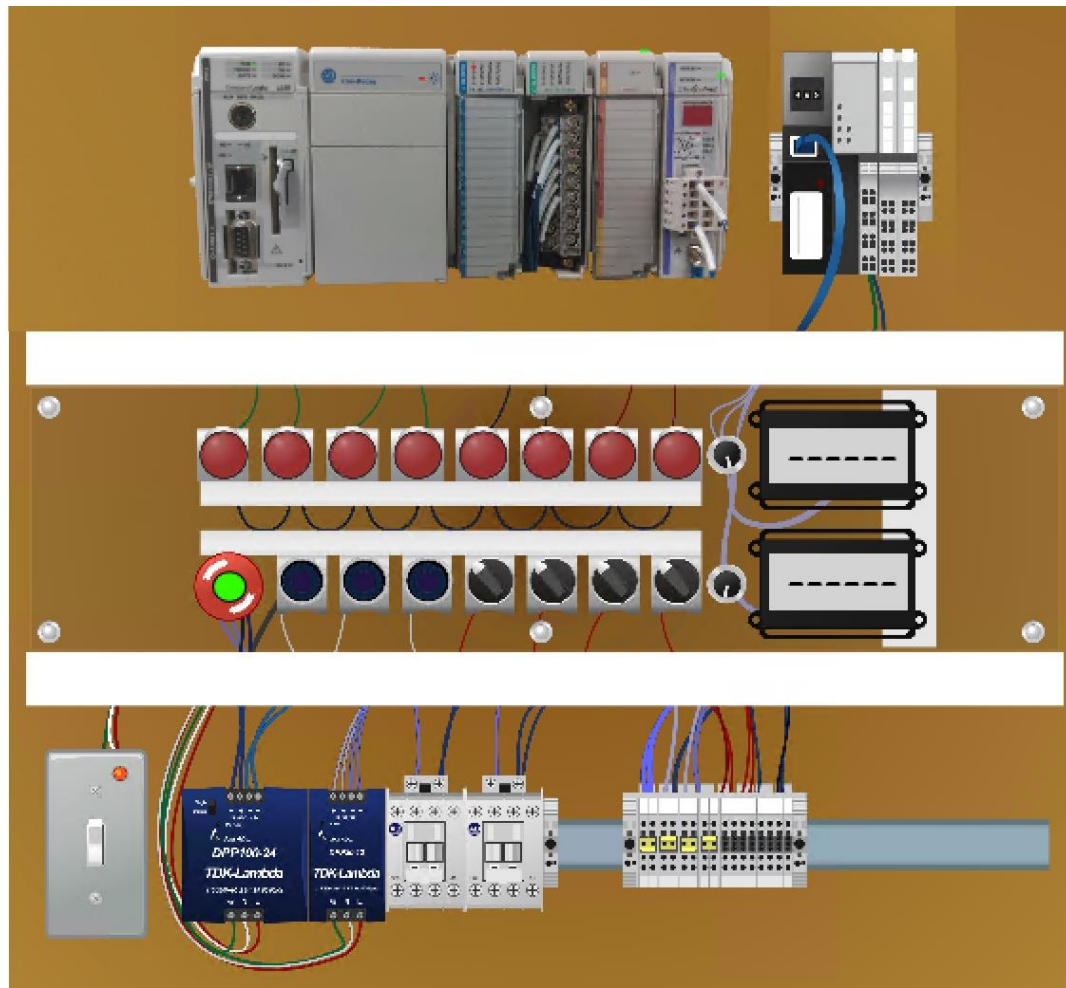

Customized Virtual Simulator

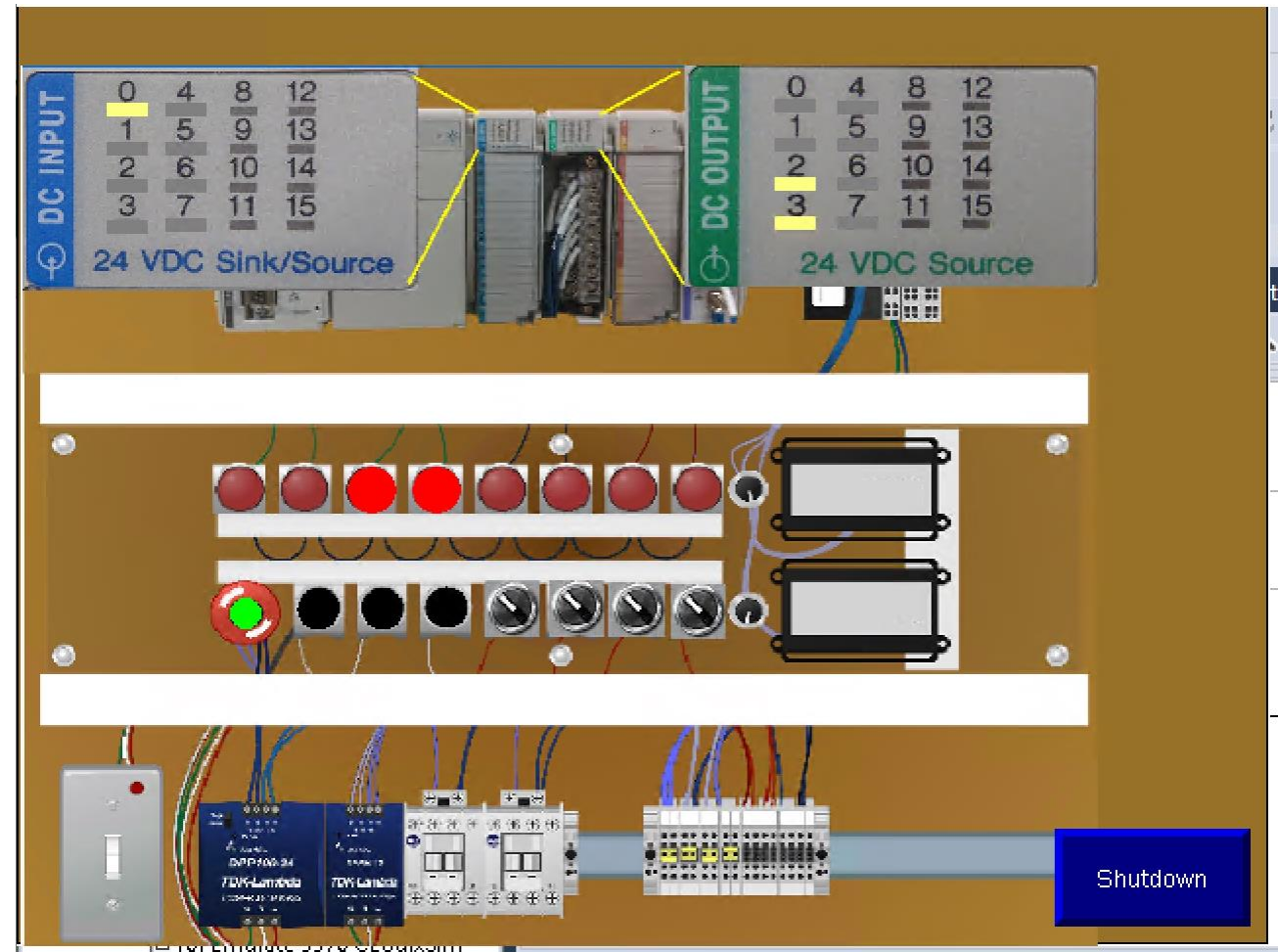

Having a CompactLogix program running in the Studio 5000 Emulator, control a pneumatic circuit in Automation Studio, using OPC communications between the applications. Both Automation Studio and the Rockwell Software are in the same Virtual Machine.

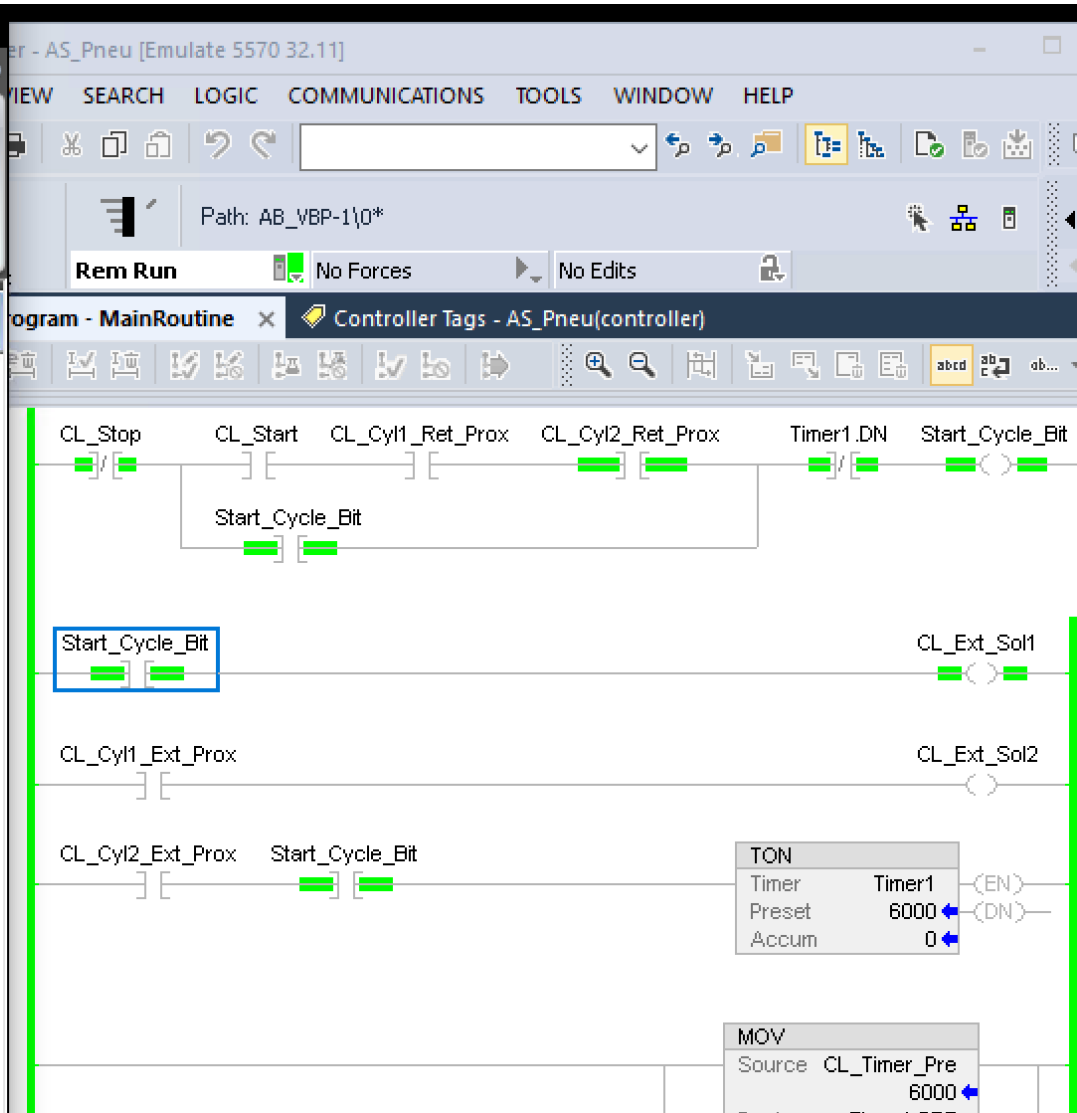
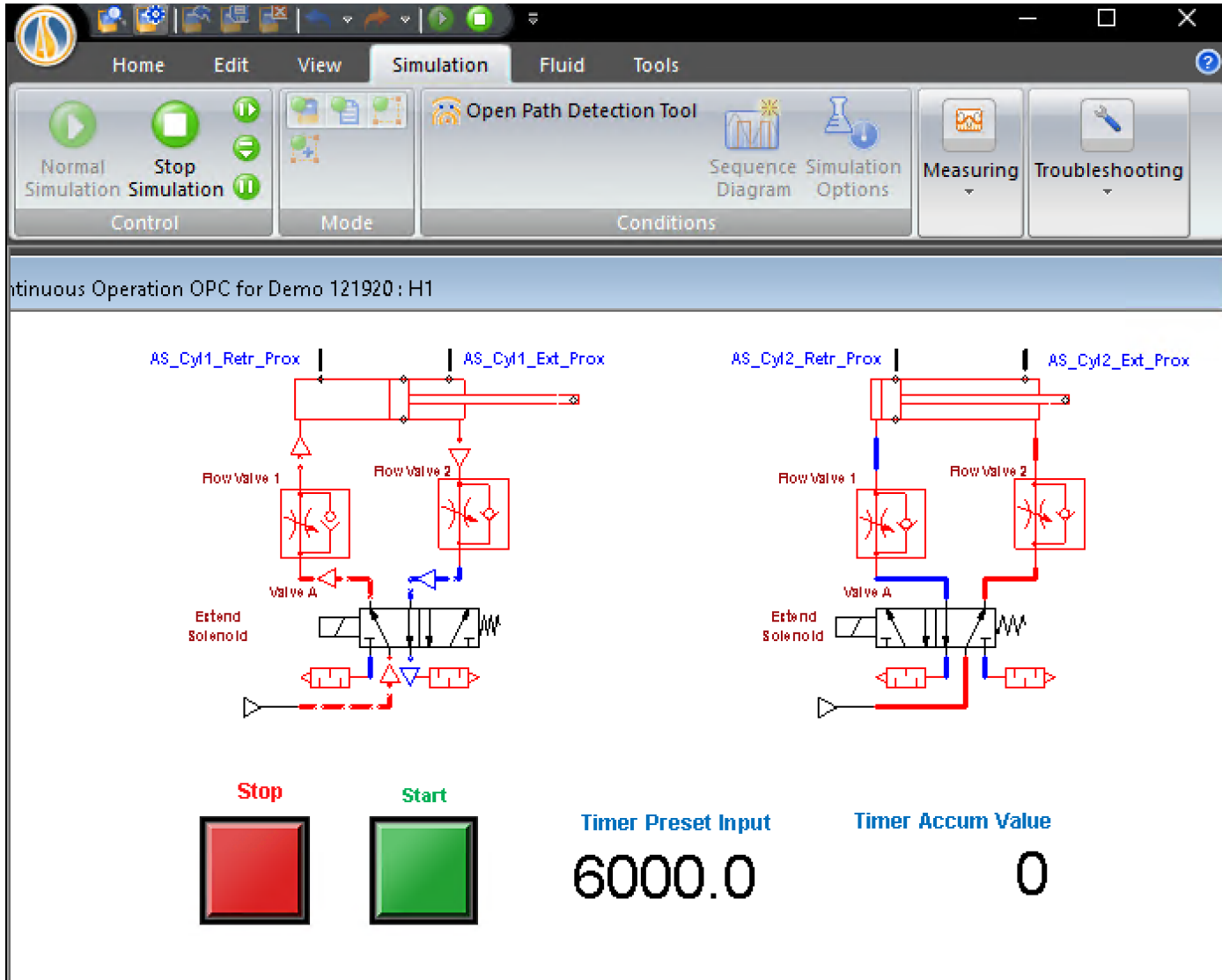



Virtual Simulator

Some Information about the Simulation Engine

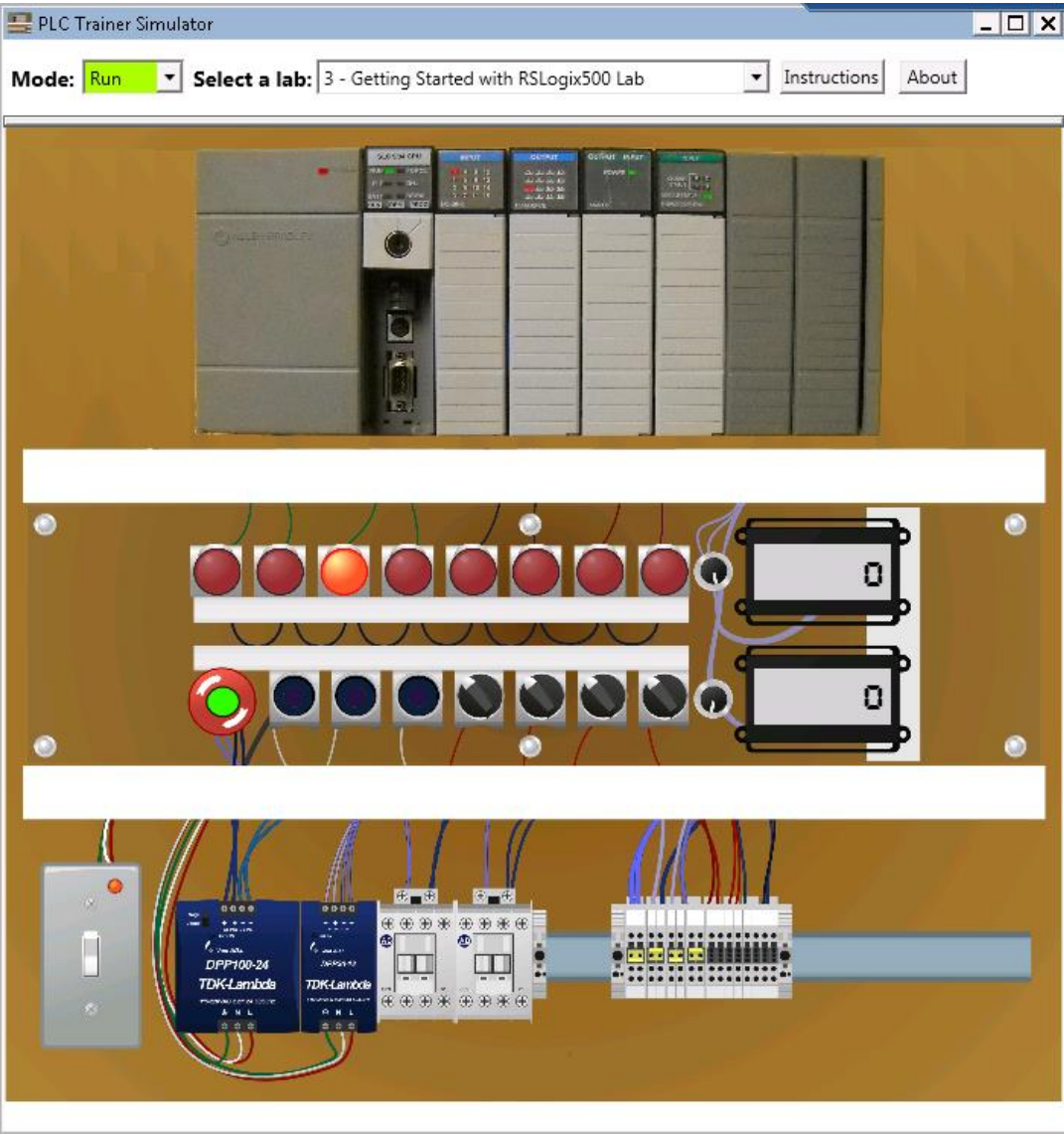

*The Engine was built in C# (C-Sharp) Programming Language

*DEMO mode to show students how a program will work. All 21 PLC I labs are embedded, then can be opened for students to view the program in the lab exercise.

*RUN mode connects the virtual simulator to the 500 Emulator through the OPC connectivity to RSLinx. Students can run their programs on the simulator that they create in RSLogix500.

*The Engine uses OPC technology to communicate with RSLinx

*The Virtual Simulator is licensed through Creative Commons, and can be downloaded from [Skillscommons.org](https://www.skillscommons.org).

Simulation in Automation Studio for basic electrical course. Multi-meter or clamp-on ammeter can be used for testing the circuit.



RMS Voltage 14.3 V

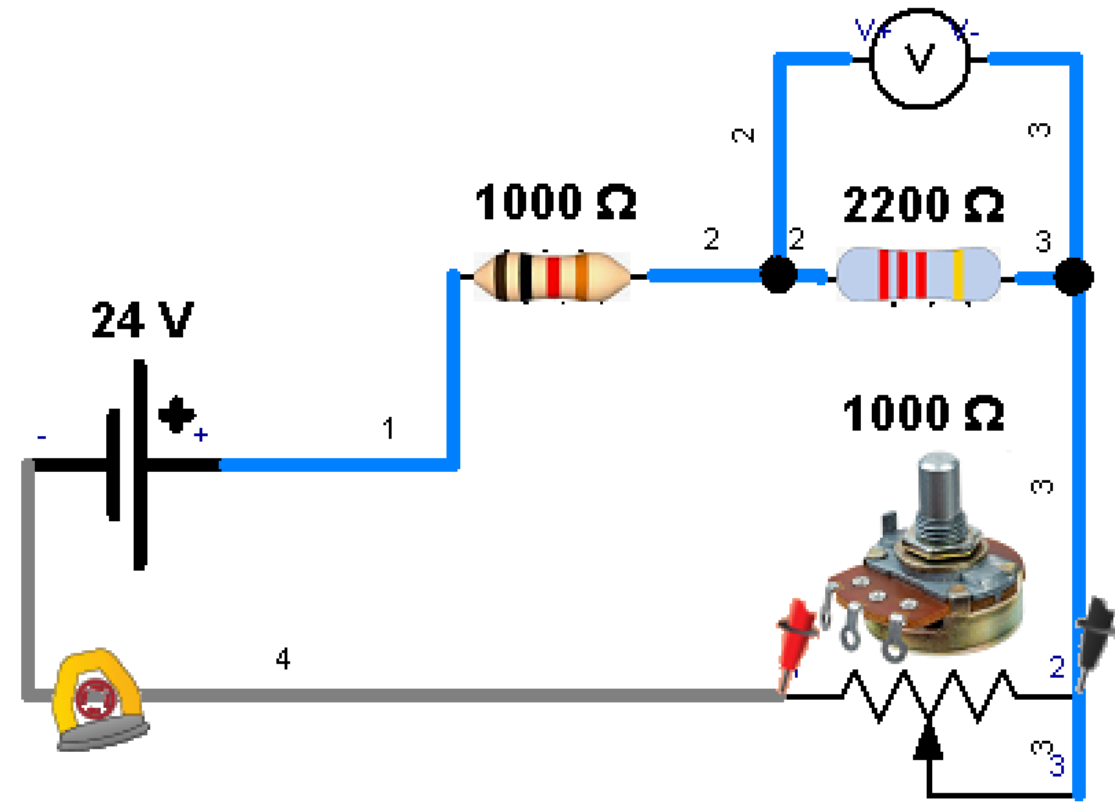

Simulation in Automation Studio for basic pneumatic circuit operation and troubleshooting

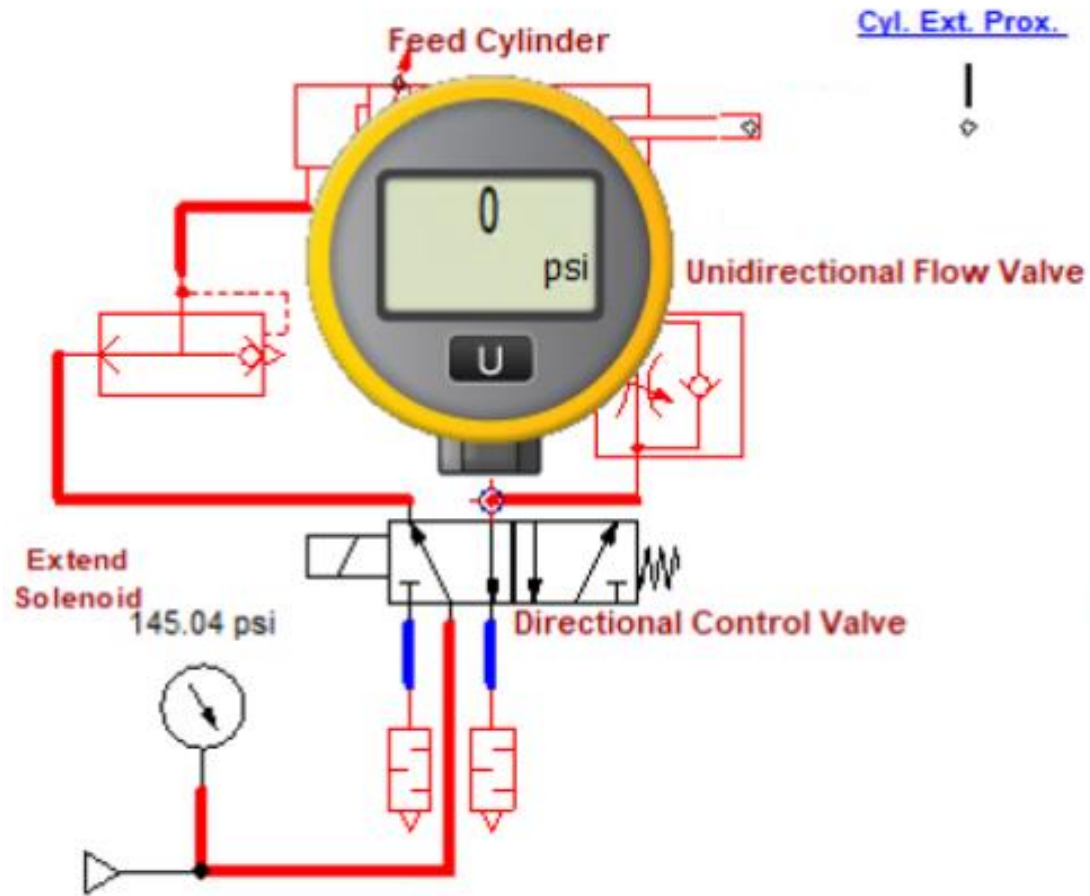

Cyl. Ext. Prox.

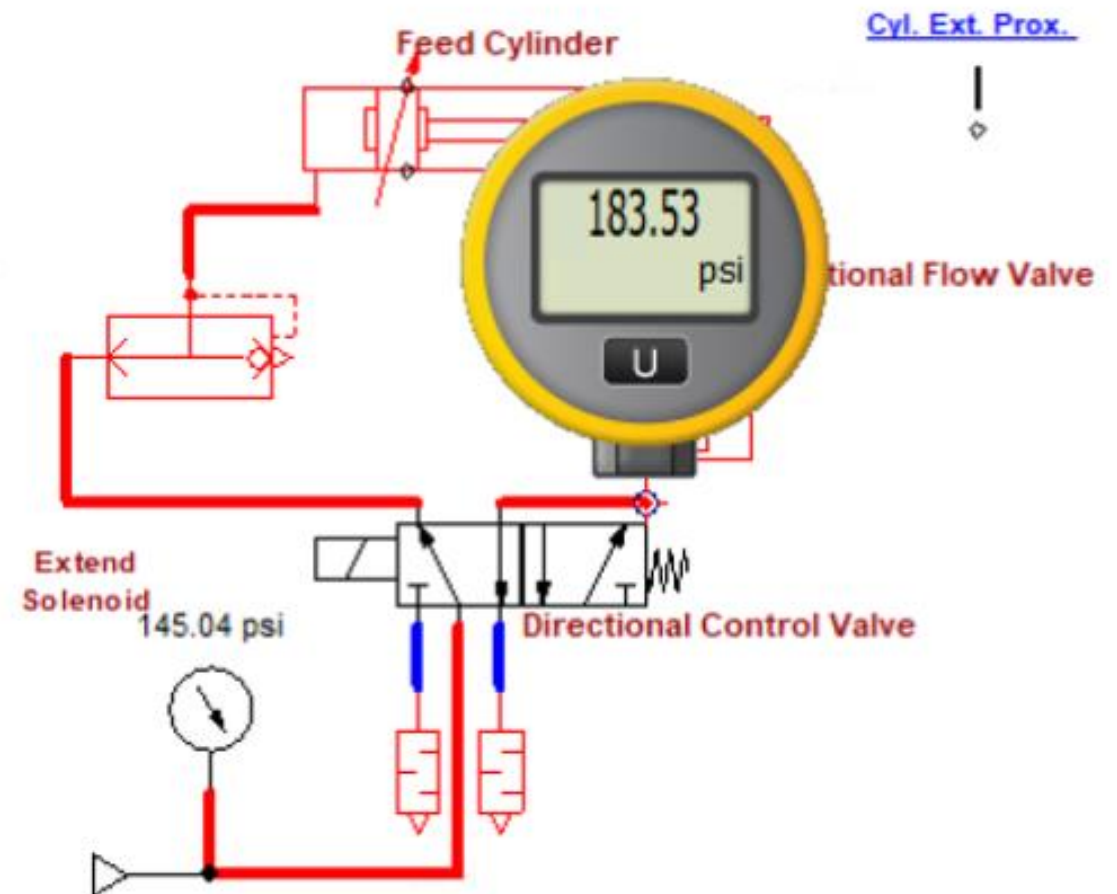

Cyl. Ext. Prox.



Simulation in Automation Studio for basic pneumatic circuit controlled by an electrical circuit

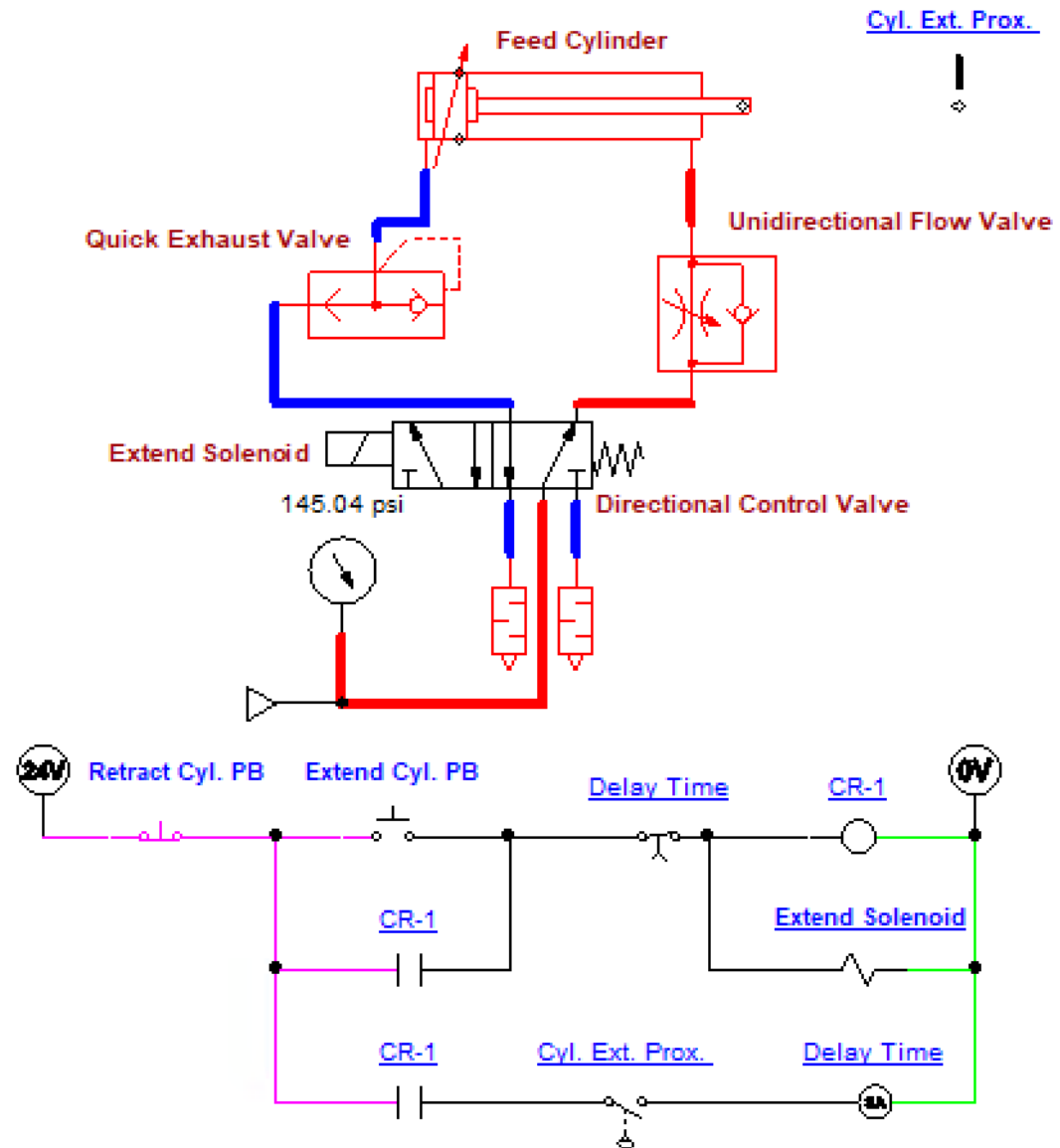



Simulation in Automation Studio for basic pneumatic circuit controlled by a PLC circuit

Lab 6:3

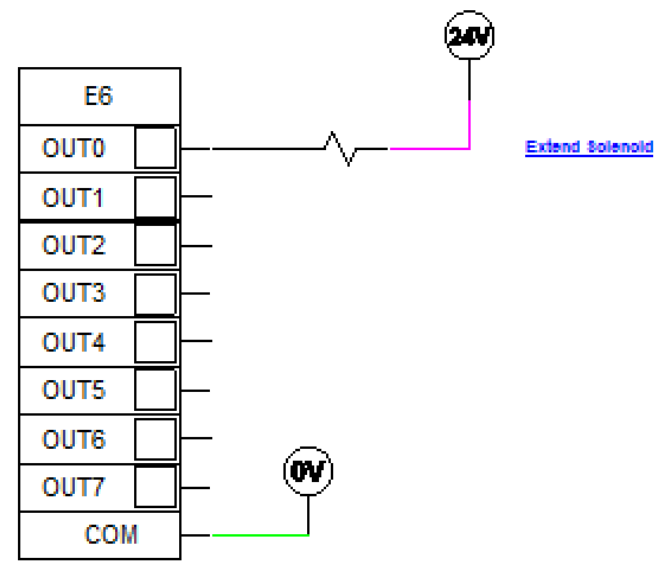
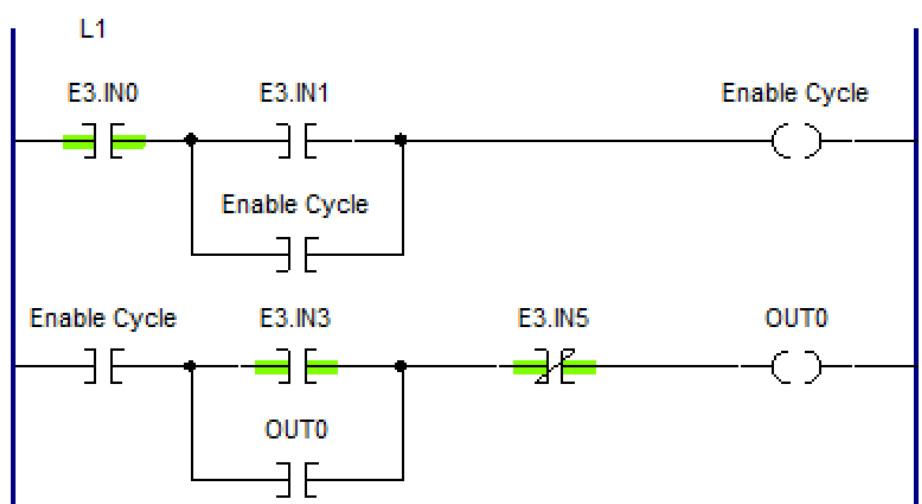
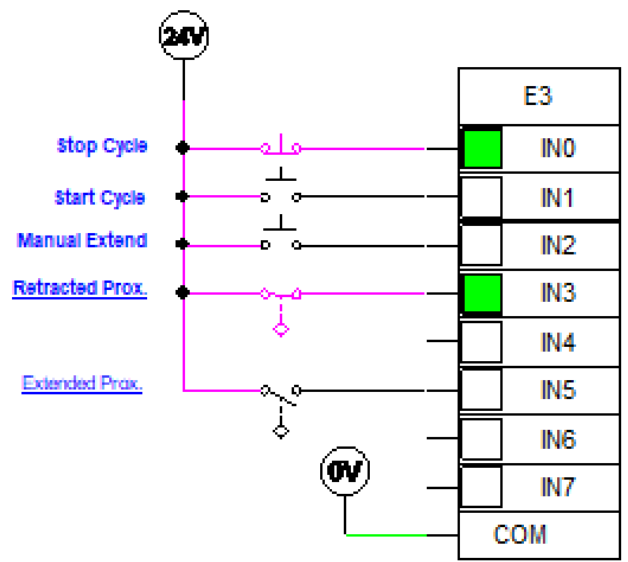
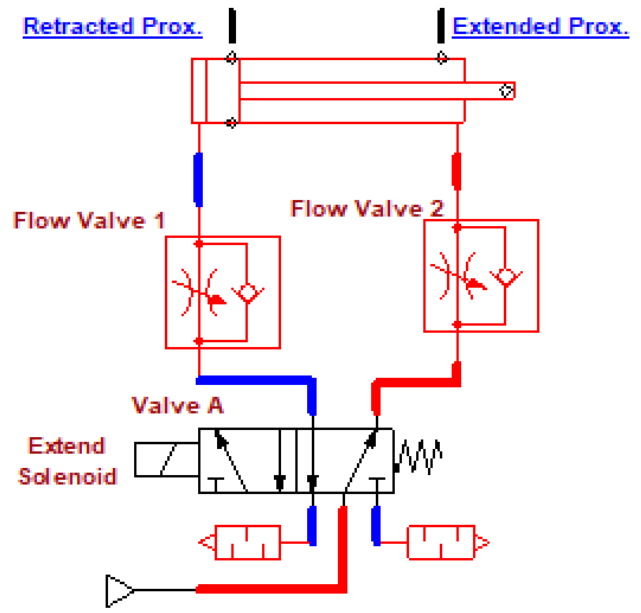



Visual objects created in PowerPoint of the simulation circuit, used to create test questions or illustrations

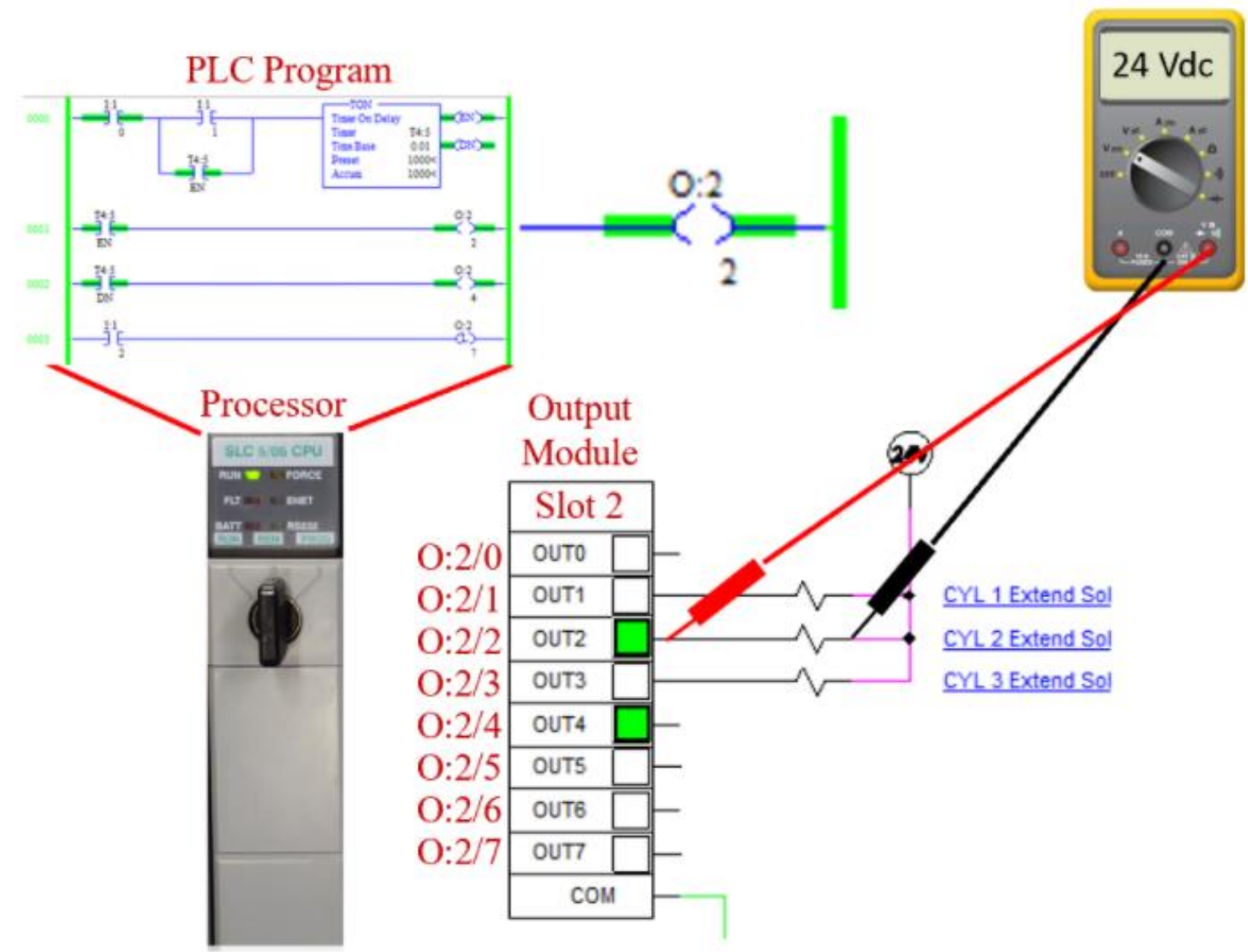



Simulation in Automation Studio of a motor branch circuit.
Students see how the control circuit and power circuit works.
Fault switch is used to open a power line for student troubleshooting.

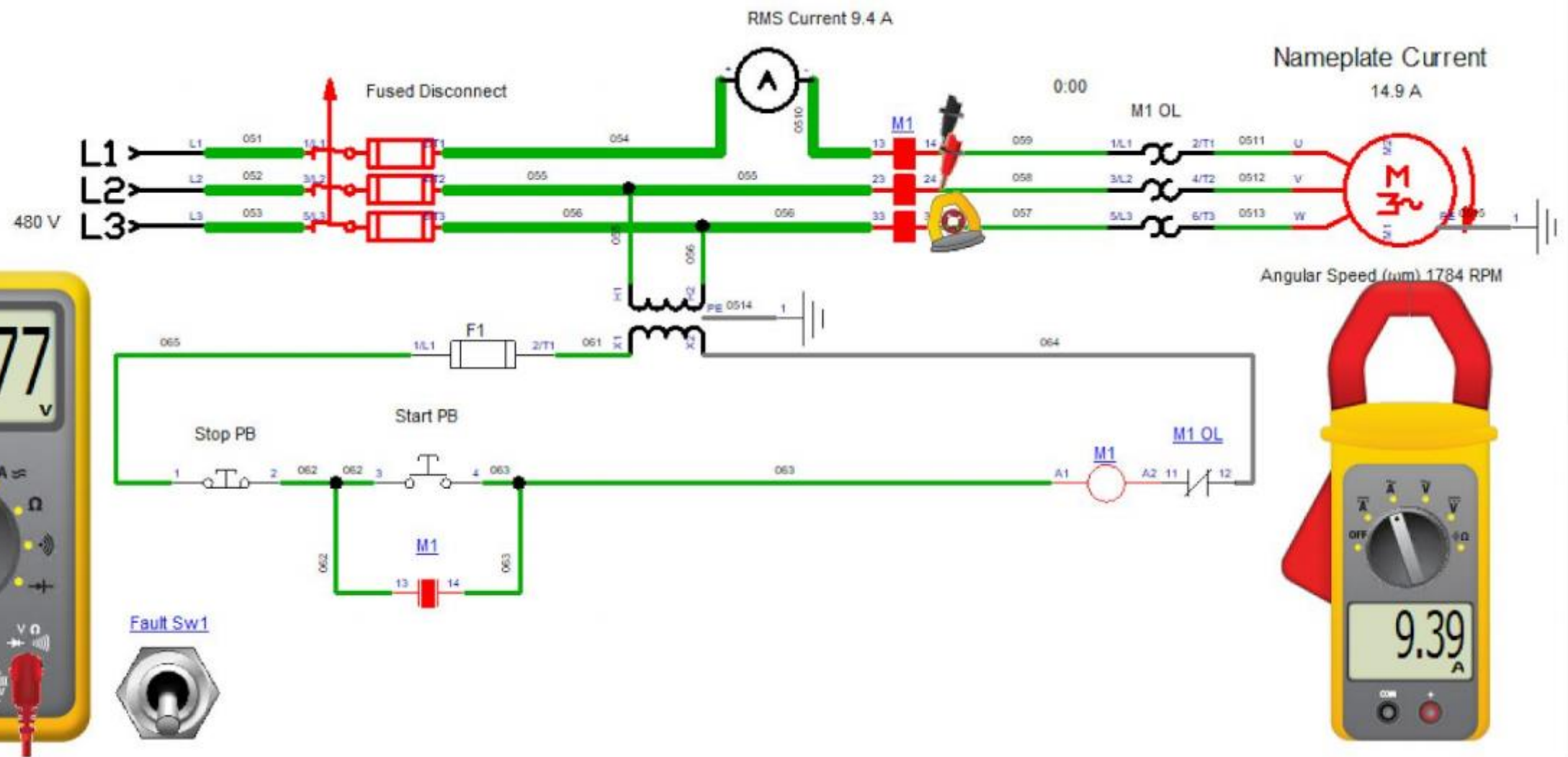

Simulation in Automation Studio for VFD operation. This simulation is using an AB PowerFlex 525. Students see how changing the frequency changes the motor speed, output voltage and power consumption.

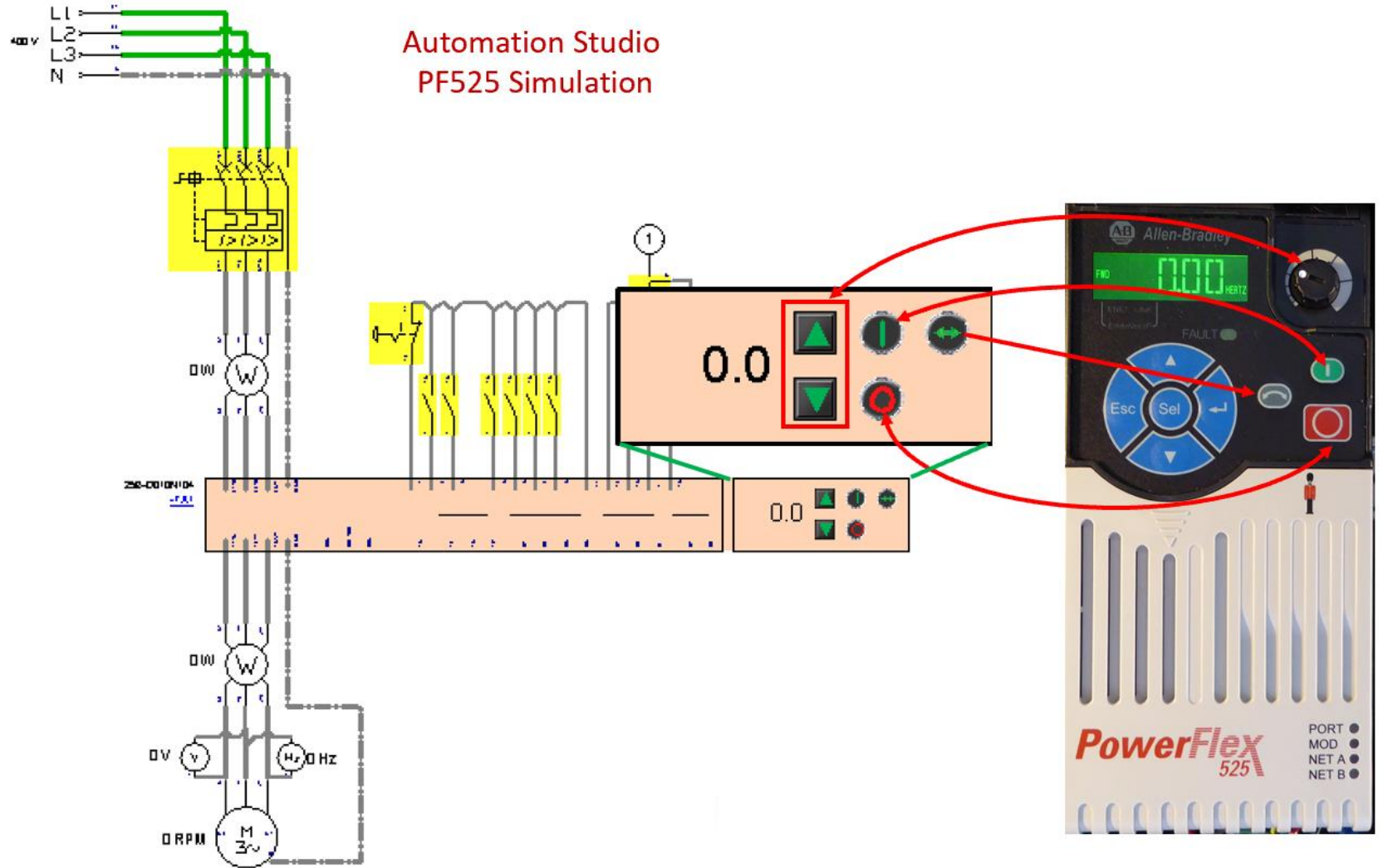

Simulation in Automation Studio for VFD operation. This simulation is using an AB PowerFlex 525. Students see how changing the external potentiometer, changes the output frequency of the drive.

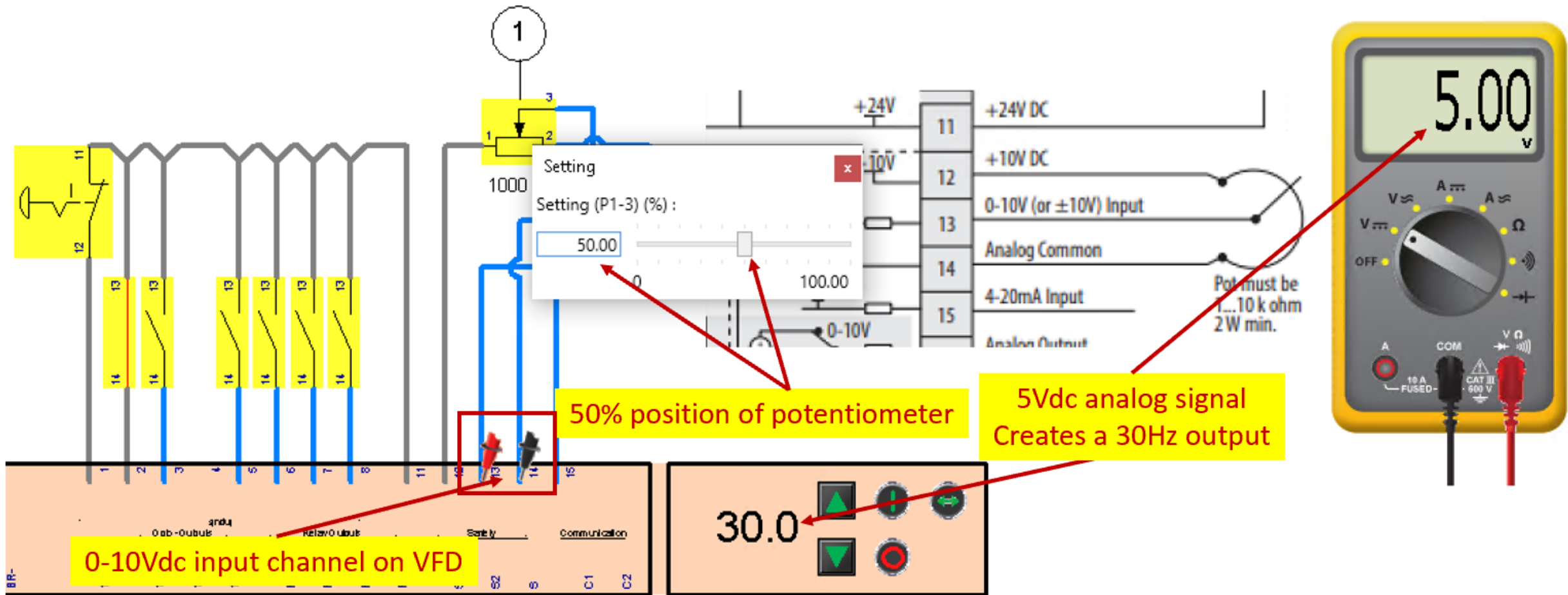

Simulation in Automation Studio of an electrical circuit, controlling a pneumatic circuit. Faults are inserted for student troubleshooting. This slide show a virtual pressure gauge, and a multi-meter used to troubleshoot the pneumatic and electrical circuits where faults can be inserted from the fault switches.

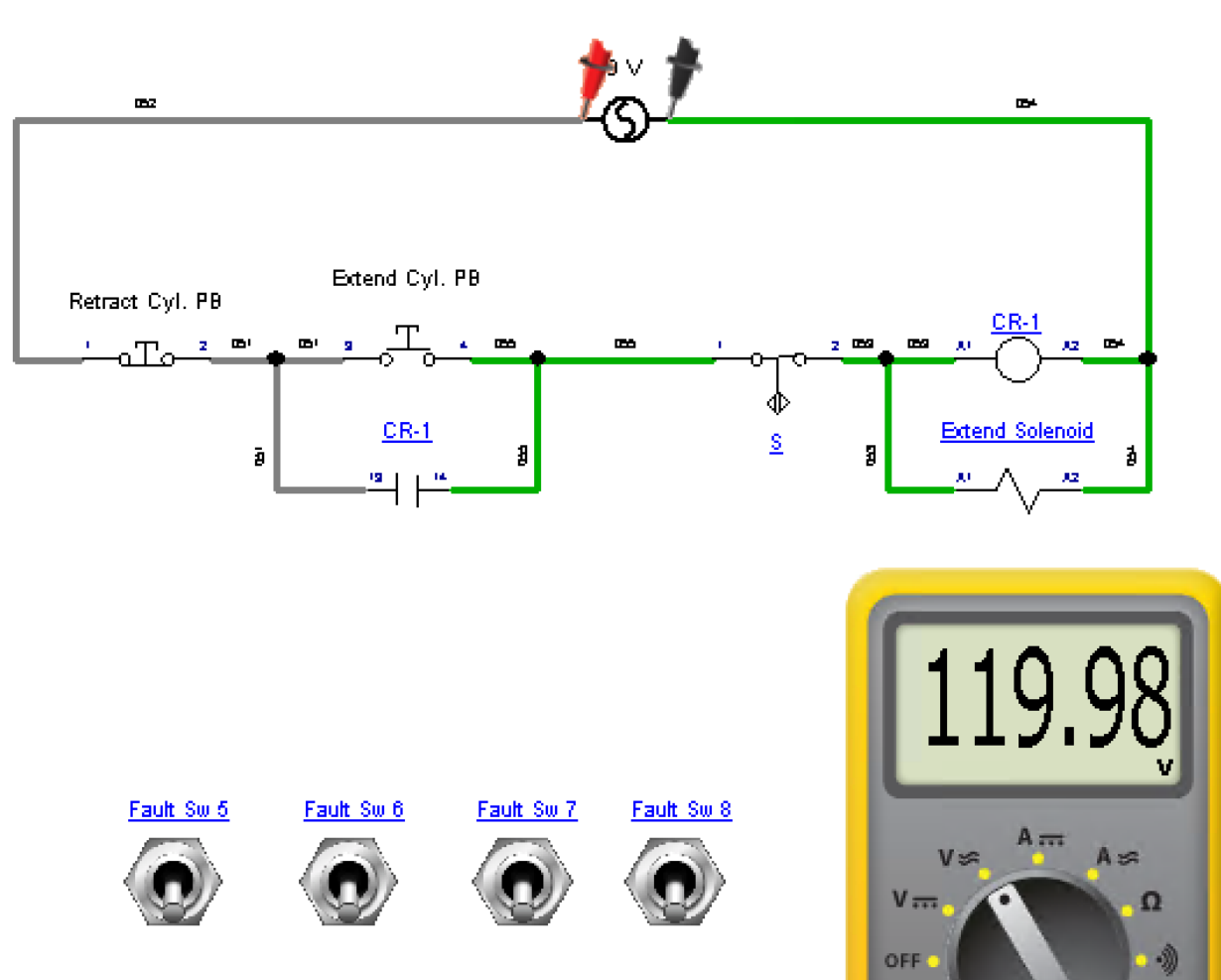
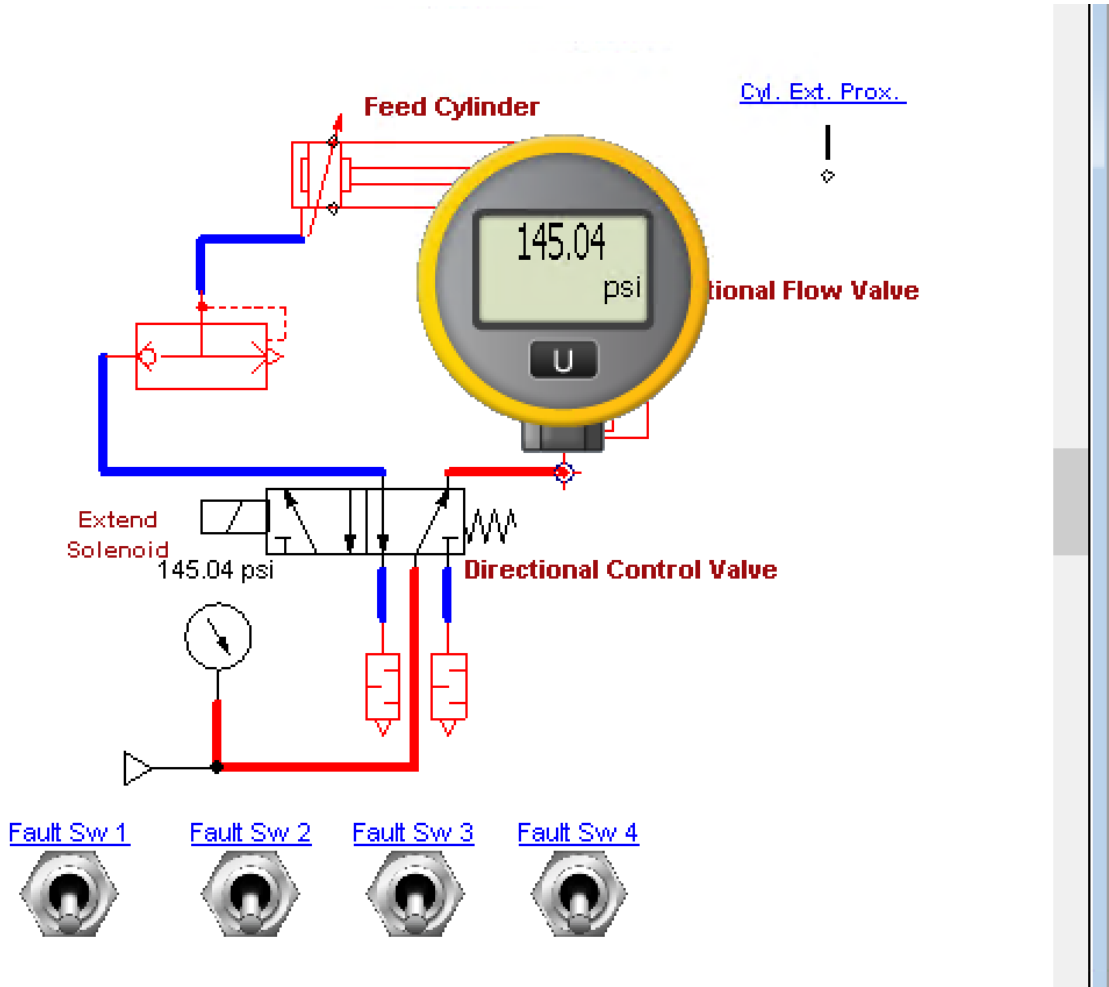

Simulation in Automation Studio of an electrical circuit, controlling a pneumatic circuit. Faults are inserted for student troubleshooting. This document is for the Instructor to reference what fault is inserted. All components and lines can have a fault inserted by the instructor, and assigned to a fault switch.

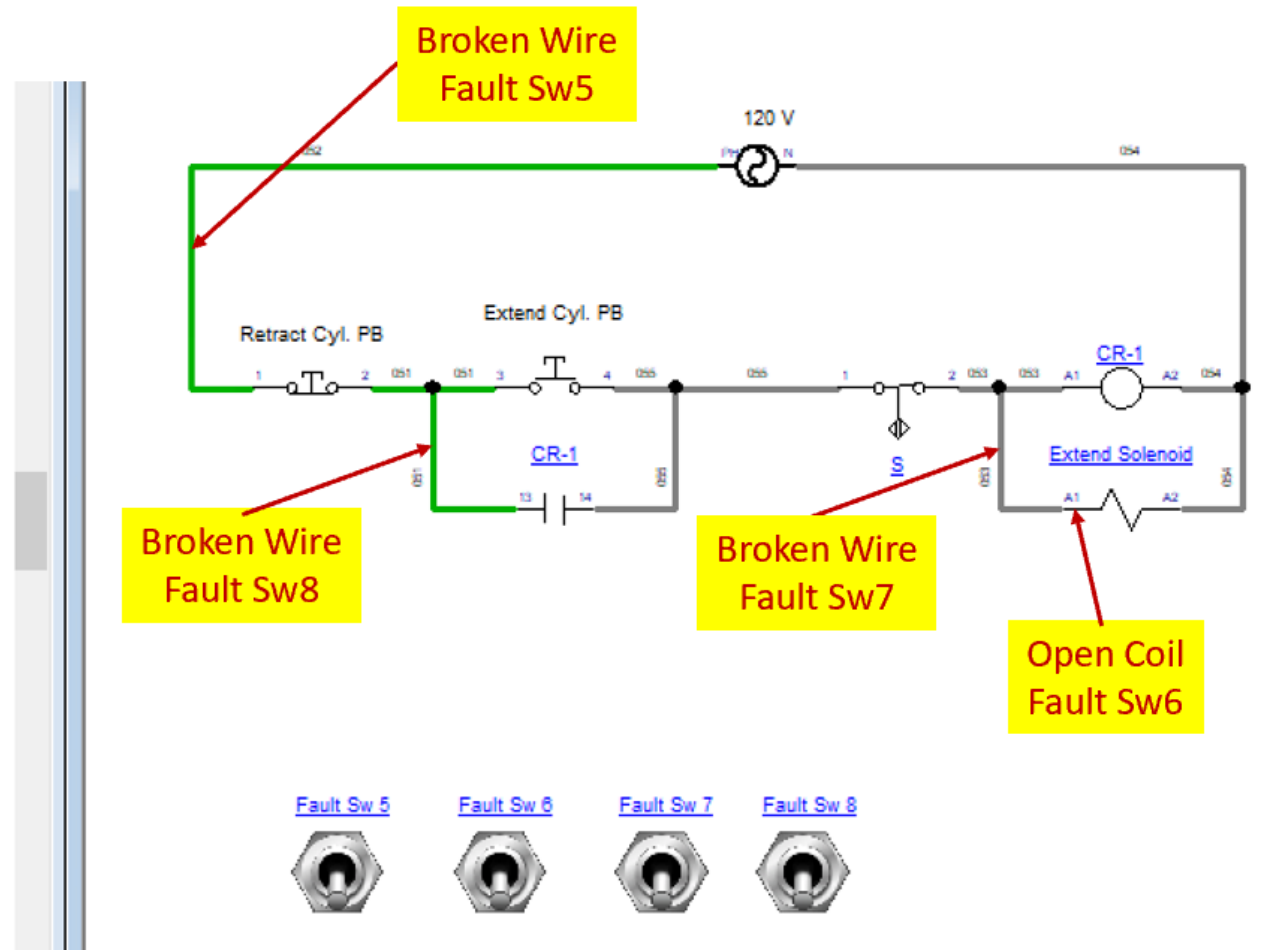
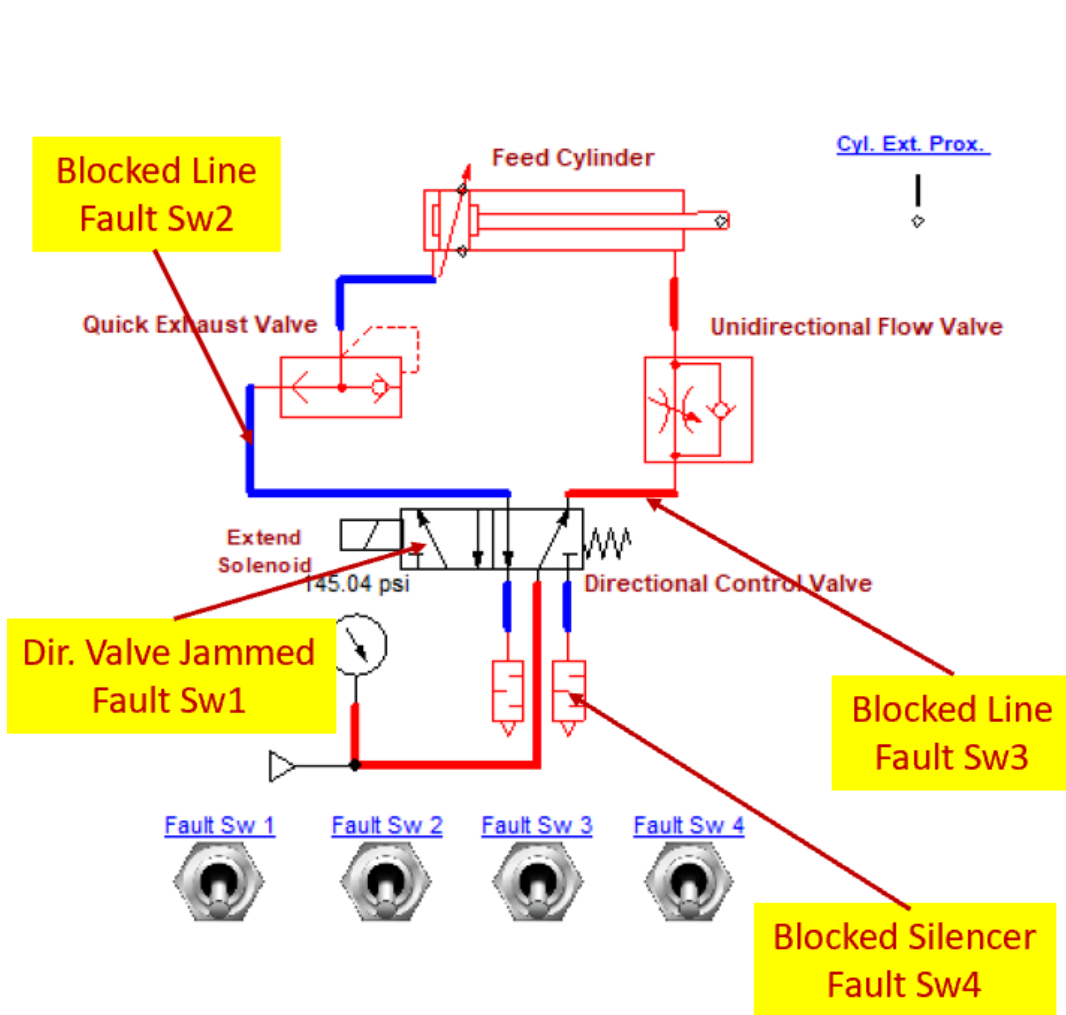



The End of the Presentation