



Faculty Workshop Session 2

For the NSF Project: “Scaling Elements of a Competency-based/
Hybrid Instructional Model in Adv. Mfg. Courses”

Presented by:

Tom Wylie, Northwest State CC, Archbold, OH
(twylie@northweststate.edu)



Scaling CBE Elements Faculty Workshop:

1. Session 1: 5/20/22, 1:00 – 3:00pm EDT
- *2. Session 2: 5/27/22, 1:00 – 3:00pm EDT
3. Session 3: 6/3/22, 1:00 – 3:00pm EDT

Handouts for the Workshop is available at the Project Website:

https://ate.is/Scaling_CBE



Quick Review of Session 1:

1. This workshop is not about converting to a CB/H model
2. If a college can improve a course with one of the element, Great!
3. Hopefully you have the autonomy to adjust courses to meet local needs
4. Every college has uniqueness that works for them
5. OER is open to use for your technical courses
6. Creative Commons licensing is important to reusing objects



Example of Improving a Technical Course:

1. Terra State CC had an interest in this project
2. FT Electrical Faculty reached out and wanted to utilize the project
3. Students were not focusing on the hands-on learning in the PLC lab
4. Employers wanted more hands-on skills
5. Project PI and Terra Faculty created one Hands-on Assessment
6. Result: Students stay in lab after class is over for more hands-on



Terra State CC PLCII Course, Hands-on Assessment

Check #	Skills Task
1.	Identify all hardware on the AB CompactLogix hardware simulator.
2.	Identify and explain all communication ports on the Compact/Control Logix processor.
3.	Configure an RS-232 driver in <u>RSLinx</u> and explain the info in <u>RSWho</u>
4.	Create a new project in Logix Designer, by configuring the I/O, and creating the alias tags in the Controller Tags settings.
5.	Create a 4 rung program in a new project with the relay and timer instructions.
6.	Download the project into the CompactLogix controller.
7.	Explain to the instructor how the program operates.
8.	Create an Ethernet driver in <u>RSLinx</u> , and go online to the Compact/Control Logix processor with the program panel.
9.	Create an <u>EtherNet/IP</u> driver in <u>RSLinx</u> , and go online to the Compact/Control Logix processor with the program panel.
10.	Explain what each processor diagnostic indicator light means under different conditions. This may also be questions asked by the Instructor on each indicator. The student should review this information before the HOA. This can be found on pages 192-198 of the ControlLogix Systems <u>Users Manual</u> , found at:

Student Procedure:

1. Create a new project, configure I/O, create the following program.

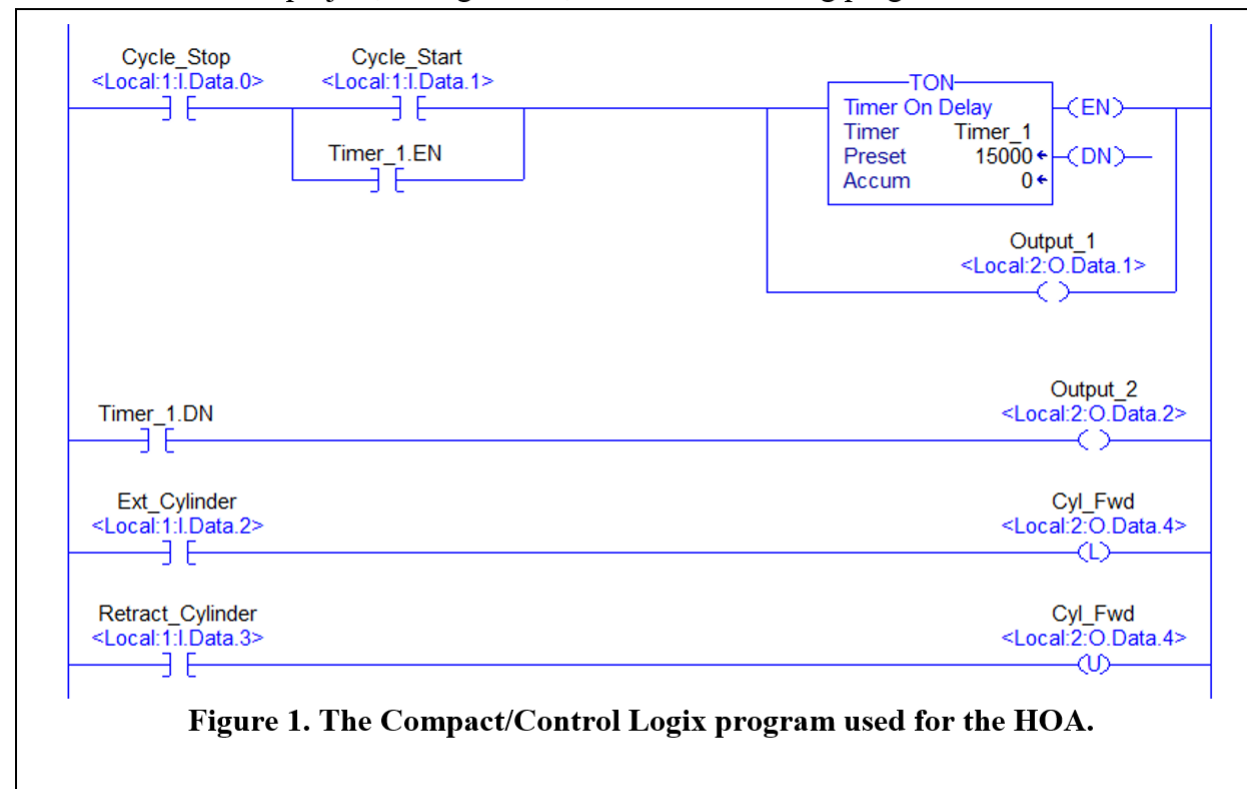

Figure 1. The Compact/Control Logix program used for the HOA.

2. Load the project into the processor, then go online. Make sure you understand how the program works and how to access the data.
3. Have the instructor come over and answer their questions on the project.



Scaling CBE Elements Wheel





Workshop Session 2 Topics:

1. Review OER and a Development Site in your course
2. Employer Engagement and Alignment
3. Tools for building Learning Objects
4. Software tools for building learning objects
5. Software tools for editing videos
6. Building PDFs and Instructional Videos

A Personal Sandbox in your LMS



TERRA STATE COMMUNITY COLLEGE

Account

Dashboard

Courses

Calendar

Courses



Published Courses

EET1630 001

Spring 2021

EET2790 001

Spring 2021

Mike

Development Shells

twylie01 development shell



Development Shells

1. It is important to have your own development site (shell) within your LMS, in order to try new things, including importing a .imsc common cartridge course
2. Make sure you have enough allocated memory for the import





A Personal Sandbox in Blackboard



 Institution Page

 Tom Wylie

 Activity Stream

 Courses

 Organizations

 Calendar

 Messages

 Grades

 Tools

 Sign Out

PTEC.1133.031.SP22 Process Instrument I

[Multiple Instructors](#) | [More info](#) ▼



Fall 2021

PTEC.1133.030.FA21

PTEC.1133.030.FA21 Process Instrument I

 Private | [Multiple Instructors](#) | [More info](#) ▼



Assorted Dates

MECH.1203.SNBX

MECH.1203 Industrial Safety SANDBOX

 Private | [Multiple Instructors](#) | [More info](#) ▼



PTEC.1113.SNBX

PTEC.1113 Intro to Process Tech SANDBOX

 Private | [Multiple Instructors](#) | [More info](#) ▼



TWYLIE.PTEC.1133

TOM WYLIE Process Instrument I

[Multiple Instructors](#) | [More info](#) ▼





Employer Engagement

There are primarily 3 types of employer engagement that we use at NSCC. Each has a specific purpose. Each type will serve as diplomacy to the external constituents (employers), but all will require a follow up to the employers on how you will improve your service to them.

1. Advisory Boards
2. Industry Roundtables
3. Focused Employer Visits



Advisory Boards

Most every technical program has an Advisory Board. Originally this was our primary way of engaging employers. Our Advisory Boards included industry personnel, graduates working in industry, equipment vendors, mid & senior level managers from industry. The focus was to:

1. Focus on the technology & skills required in an academic tech program
2. Avenues for employment of graduates
3. Sources for donated equipment and help in purchasing equipment
4. Partnership tasks, such as commitment letters for grants



Industry Roundtables:

This differs from an Advisory Board in that we are focused on one problem that needs to be solved. Curriculum alignment is the best focus of a roundtable, but also getting input from a group of employers. Here are examples of how we use roundtables:

1. Determine the topic/technology content of a course
2. Trends in technology, and how much we should implement
3. SWOT analysis on the services and programs at the college
4. Great success with Maintenance Team Leaders



Focused Employer Visit:

This is the most time consuming form of engagement, but it is also one of the most valuable for the college to actually see what a company is doing, and what tasks the employees have to perform.

1. Builds great relationships with the employers
2. The employers take pride in their companies, and want to show it
3. Employers can also visit the college to see your equipment
4. An important way to mend fences
5. Take the President/Vice-Presidents with you, so they can learn



A Thin Slice of Curriculum Alignment

1. Moved from Syllabus to Course Info Sheets for Employers
2. For a roundtable, do not give them too little, or too much, usually 2-5 pages
3. Show current course topics, then some from other sources
4. Topics are then identified (agreed upon) then modularized

Reverse Design:



It is best to initially run the course in a standard format, to establish the correlation between content and credit/contact hours. This establishes baseline data for the cross walk between competencies and credit/contact hours.

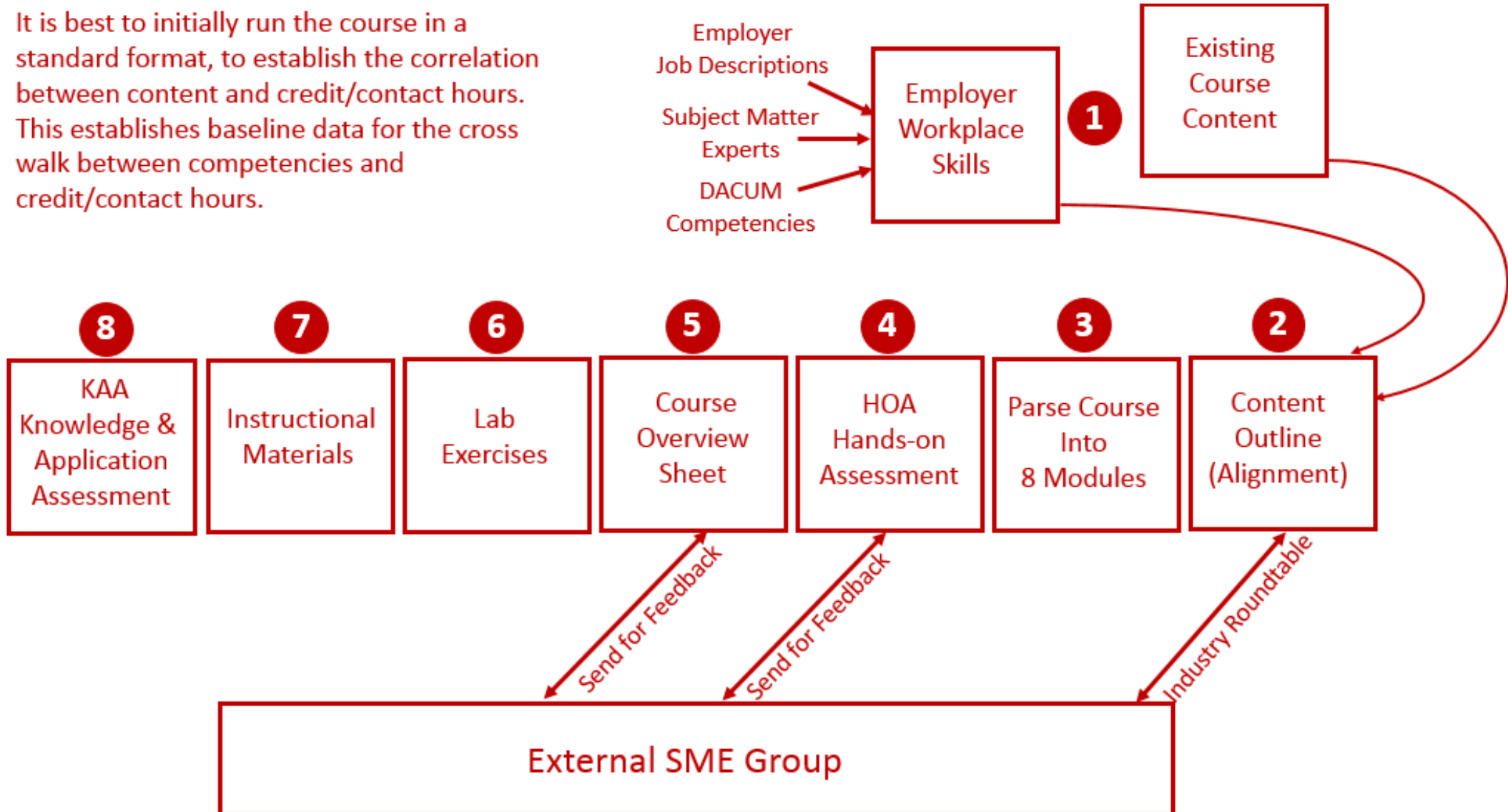



A Thin Slice of Curriculum Alignment:

1. Competencies and HOA tasks are shown in the Course Overview
2. Alignment to the actual Hands-On Assessment
3. Employers have an in depth look at course content
4. We started with the sequence of courses: Course Sequence.
5. Alignment to academic standards are critical
6. Learning Sequence Sheet is very valuable for each module

ACTIVITY	DESCRIPTION	TIME ON TASK	POINTS
Reading Activity	Troubleshooting Electrical/Electronic Equipment, by Mazur and Proctor, Third Edition: <i>Chapter 5</i> – Meters Pgs. 93-107; *Multimeters, *Test Lights, *Voltage Testers, *Voltmeters, *In-Line Ammeters, *Clamp-On Ammeters, *Ohmmeters, *Continuity Checkers, *Wattmeters <i>Chapter 8</i> – Relays and Motor Starters Pgs. 167-174; *Relays <i>Chapter 9</i> – Troubleshooting Relays and Starters Pgs. 183-184; *Troubleshooting Electromechanical Relays	Est. TOT 5.0 Hr.	
Learning Activity	Learning Activities: * PDF: IND220 Module 1 Basic Electrical Overview.pdf * PDF: IND220 Module 1 Basic Relay Concepts 081520.pdf * Video: Getting into the Virtual Machine to run the Simulations * Video: Explanation of IND220 Lab 1.1 Circuit 1 * Video: Explanation of IND220 Lab 1.1 Circuit 2 * Video: Explanation of IND220 Lab 1.3 Circuit 1 081520 * Video: Explanation of IND220 Lab 1.3 Circuit 2 1073120	Est. TOT 4.0 Hr.	
KAA	IND220 Module 1 KAA Study Guide.pdf IND220 Module 1 KAA Practice Quiz IND220 Module 1 Knowledge & Application Assessment (KAA)	Est. TOT 3.0 Hr.	Min. of 80%
Lab Exercise	IND220 Lab 1.1 AS Basic Relay Circuit (Automation Studio files included in Sakai)	Est. TOT 1.5 Hr.	
Lab Exercise	IND220 Lab 1.2 HL Basic Relay Circuit.pdf	Est. TOT 1.5 Hr.	
Lab Exercise	IND220 Lab 1.3 AS Troubleshooting a Relay Circuit (Automation Studio files included in Sakai)	Est. TOT 1.5 Hr.	
Lab Exercise	IND220 Lab 1.4 HL Wiring a 3-Wire Control Circuit	Est. TOT 1.5 Hr.	
Hands-On Assessment	Hands-On Assessment for Module 1	Est. TOT 1.0 Hr.	Min. of 100%
TOTAL		Approx. 19 Hrs	18-20 hrs. per week

Academic Standards:

1 Lecture hr should need
2 hrs outside of class

1 Lab hr should need 1 hr
outside of class

Estimate the amount of
time to complete the
module

This document shows the
cross walk for academic
affairs



What are Learning Objects:

1. Learning Objects are housed in the course within the LMS
2. Common objects are the textbook and PDFs
3. Videos and voice over PPT are the most effective objects
4. Interactive simulations will be covered next session
5. Study guides and quizzes/tests are also learning object
6. A very effective object is formative assessments with feedback
7. Example 1 of formative assessment with feedback

Example of an NSCC Practice Quiz Question

“Formative Assessment with Feedback”



13. From the following cross reference report, what program file and rung number is CTU for C5:11 stored in?
- 3:2
 - 2:91**
 - 3:91
 - Cannot determine from this report

The screenshot displays a 'Cross Reference Report - Sorted by Address' window. The report lists the following entries:

Address	Description
C5:4	(CTU_FREE)
CTU	File #3 PID_SUB_RT - 2
RES	File #3 PID_SUB_RT - 3
C5:4/DN	XIC - File #3 PID_SUB_RT - 3
C5:6	(COUNT_DOWN)
CTU	File #3 PID_SUB_RT - 4
RES	File #3 PID_SUB_RT - 5
C5:6/DN	XIC - File #3 PID_SUB_RT - 5
C5:11	(GET_STACK)
CTU	File #2 MAIN_LADDR - 91
C5:12	(DISPENSER_TR_1) Dispenser Transferred 1 Bottle

The ladder logic diagram shows a rung with a CTU instruction. The focus (cursor) is on the XIC of B3/4 on rung 91. The location of the focus is listed as 2:0091 at the bottom of the ladder view.

Annotations in red:

- "The focus or formerly called the cursor" points to the XIC of B3/4 on rung 91.
- "This number shows the location of the focus (cursor)" points to the number 2:0091 at the bottom of the ladder view.

Explanation: In this graphic, the Cross Reference Report shows that the CTU for C5:11 is located on rung 2:91 (Program file 2, rung 91). This means the rung is in ladder file 2 (as shown in the upper right of this graphic). In the lower right portion of the graphic, the rung where the CTU is located is shown. Also notice that the focus (cursor) is on the XIC of B3/4 on rung 91. At the bottom of the ladder view, the location of the focus (cursor) will be listed based on the program file and rung number.

Only use PDFs and Links to Videos in LMS



Readings and Learning Activities:



Complete the following assignments to ensure you have the proper knowledge and skills needed to successfully pass the Knowledge and Application Assessment (KAA) and the Hands-On Assessment (HOA).

► Learning Activity - Videos and PDFs that explain basic electrical circuits and troubleshooting

 [PDF: IND220 Module 1 Basic Electrical Overview.pdf](#)

This is an updated PDF from Industrial Electrical I course. Multiple KAA questions were created from this material.

 [PDF: IND220 Module 1 Basic Relay Concepts 081520.pdf](#)

 [Video: Getting into the Virtual Machine to run the Simulations 081420](#)

 [Video: Explanation of IND220 Lab 1.1 Circuit 1](#)

 [Video: Explanation of IND220 Lab 1.1 Circuit 2](#)

 [Video: Explanation of IND220 Lab 1.3 Circuit 1 081520](#)

 [Video: Explanation of IND220 Lab 1.3 Circuit 2 1073120](#)

It is important to insert only PDF files and links to MP4 and simulation files in the LMS. The reason for this is that most portable devices have a PDF reader and video player.

I have saw LMS content with MS Word and MS PowerPoint files inserted. The problem is that if the student does not have these on their computer (or device), they will not be able to open the files.



Only use PDFs and Links to Videos in LMS

Lab Opportunity:

It is a good idea to practice these labs several times to ensure that you will perform well when you take the Knowledge and Application Assessment and the Hands-On Assessment.



- Contact the lab instructor for extra lab time using the machines to practice mastering the skills listed in the module Hands-on Assessment (HOA).
- The more you practice, the more you will build skills that are marketable to industry employers!

 [IND220 Lab 1.1 AS Basic Relay Circuit.pdf](#)

 [IND220 Lab 1.2 HL Basic Relay Circuit.pdf](#)

 [IND220 Lab 1.3 AS Troubleshooting a Relay Circuit.pdf](#)

 [IND220 Lab 1.4 HL Wiring a 3-Wire Control Circuit.pdf](#)

It is important to insert only PDF files and links to MP4 and simulation files in the LMS. The reason for this is that most portable devices have a PDF reader and video player.

Learning Objects that Navigate the User



Narration

3 of 31

SCREWDRIVERS

Navigation controls: Play/Pause, Progress bar, Refresh, Previous (PREV), Next (NEXT)

Some learning objects will navigate the user through the learning object. This object paces the student through a lesson and may include some formative assessment questions along the way.

This example is a learning object on hand tools from Wisc-online.

These objects are typically created either of these two software packages:

Articulate Storyline

Adobe Captivate

This software is typically used by an instructional designer. Seldom do faculty use this software.



Navigating in Wisc-Online:

These red lines represent four conductors, which are pipes or holes through which hydraulic fluid flows.

It is called a 4-way, 2-position directional control valve.

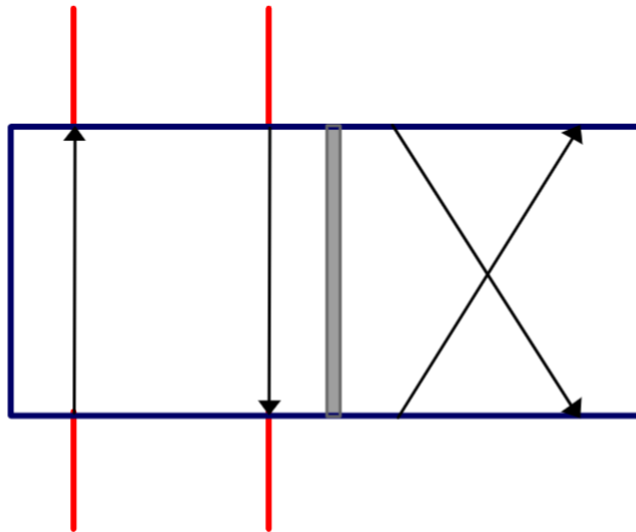

In the Wisc-Online learning object, the user must navigate to the next screen by clicking the Next button in the lower right of the screen.

The user can also repeat a slide by clicking the Back button.



Learning Objects the User Navigates



Videos

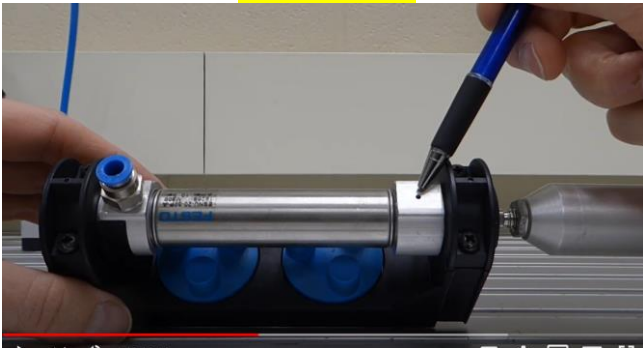

PPT/PDFs

Solenoid Coil:

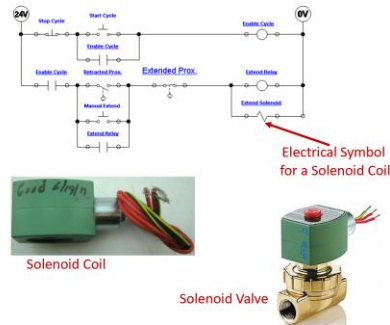

This slide shows the electrical circuit for the continuous operation circuit.

The most important part of this is to identify the solenoid coil symbol in the last rung of the circuit. This example shows a 2-way valve (2 ports). It is a valve that opens or closes off the flow of air, fluid, gas, etc.

The most important thing about these valves is that they have 2 parts: The valve (spring and plunger) that is actuated by the magnetic force of an electric solenoid. This type is termed an ASCO (manufacturer), red hat, due to the red cap. The cap is removed with a screwdriver, then the coil can be removed. If the device is on, you will feel the magnetism with a screwdriver. Sometimes the coil is bad (it opens), or the plunger sticks and must be replaced.

An important thing to remember is that if the coil is 120Vac, and is removed from the valve with power still on, a screwdriver must be inserted into the opening in the coil to keep the coil from burning up. No need to do this with a 24Vdc coil.

Voice over PPT Video

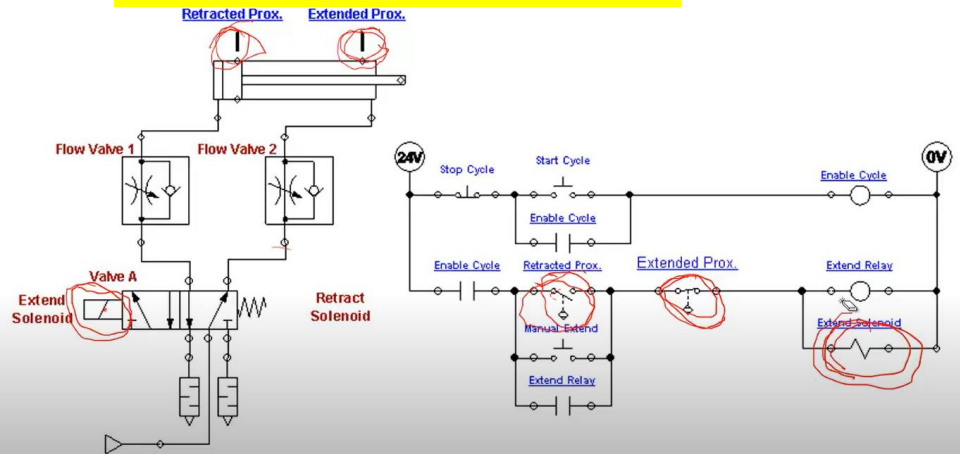

Independent Learning Objects are posted in an LMS for student access. These objects can be viewed in any sequence. The upper left graphic shows a video that was shot with a camera, explaining a single acting pneumatic cylinder.

The middle graphic is a PPT that will be converted to a PDF, then posted in the LMS.

The bottom graphic is a voice over PPT, where the graphic was put into PPT, then annotated with a stylus on the computer touch screen.

All of these objects can be viewed on a smart phone, phablet, tablet or computer screen.

Cameras for Creating Videos:

One of the common tools that our Industrial Technology Instructors use is a simple Panasonic Point and Shoot camera. It is small with a zooming lens, with a removeable SD card, and a very sensitive internal microphone. The inverting tripod allows us to position the camera upside down to shoot onto an object or whiteboard (laying on a desktop). One of the most powerful features is the Panasonic Image app that runs on the smartphone. The camera has its own WiFi portal, thus the phone connects to it, then the image app controls the camera zooming, taking photos and taking videos. The SD card is removed then put into a port on the computer where it is then transferred to the HD, and produced with the Camtasia Producer software.

Panasonic Lumix Point & Shoot



Inverting Tri-Pod



Panasonic Image Smart Phone App

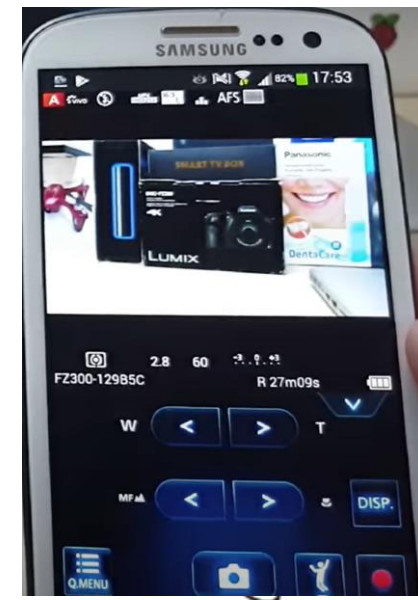

Cameras for Creating Videos:

I also use a high end camera when I need to use different lenses, use different lighting filters and want higher quality images and videos. This is primarily if I am doing something for a vendor who needs a little higher quality than for instruction. I can get UHD 4K video quality. Usually \$700+. It also has a removeable SD.

Olympus E-M10 Mark III





GoPro Cameras:



GoPro Recording of Video:

Improving the Effectiveness & Access of Advanced Manufacturing Courses by
Scaling Elements of a Competency-Based/Hybrid Model
Faculty Training & Innovation

Compass/24x7 Alignment
Employer Engagement
Hands-On Skills Assessments
Applied Online Assessments
Assessment Model (PLU)
Lab Experiences, Workplace Skills
Innovative Online Simulations
Virtual Machines, 24/7 Software Access
Modularizing Course Content
Lecture Moved Online
Active Learning Objects
LMS Migration
Flexible Lab Scheduling
CBE Skills Mastery Flexible Pacing



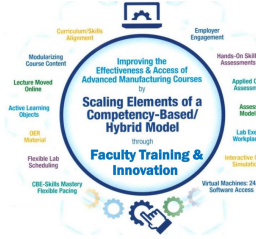

Software used to Create Objects

TechSmith (Techsmith.com), located in Michigan, developed and distributes Snagit and Camtasia. These products are targeted toward Faculty. They are simple to use and give immediate results. Snagit is an image or video capture software, and Camtasia is a product with multiple uses, but in the end it produces high quality videos. MP4 is the preferred video format for creating instructional videos. MS PowerPoint is the other key software that is needed to create illustrated graphics and animations. Google Slides does not have all of the features that MS PowerPoint has.



Snagit 2019



Camtasia 2019 Recorder



Microsoft PPT



Snagit 2019 Editor



Camtasia 2019





TechSmith Snagit 2019 (Capture):

This is the interface for Snagit capture. The user can designate a hot key such as the “PrtSc” key (Print Screen), which will bring up the cross hairs for capture.

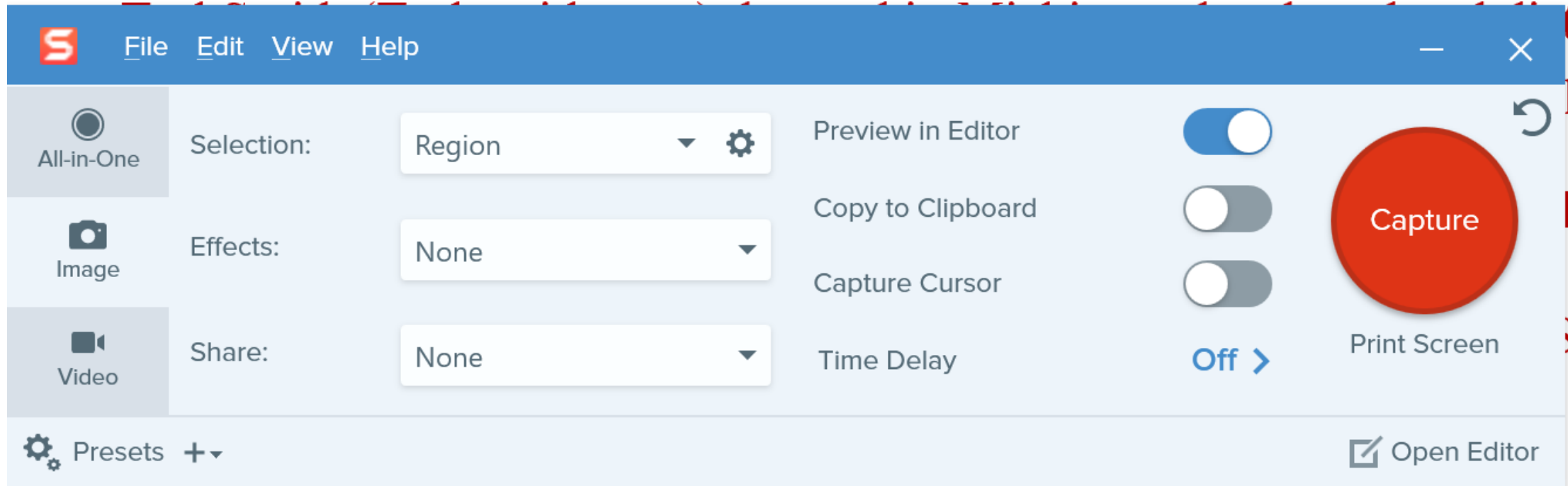

Windows 10 Snipping Tools

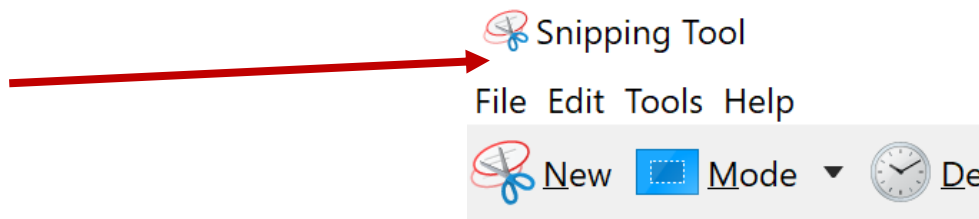

TechSmith Snagit 2019 Editor:

Tools to modify the image

The screenshot displays the TechSmith Snagit 2019 Editor interface. The main workspace shows a circuit diagram with several annotations: a red arrow pointing to a 'Fused Disconnect' (A), a red circle around a motor symbol (M1) with 'Nameplate Current 14.9 A' (B), a red circle around a component (C), a red circle around a component (D), a red circle around a component (E), a red circle around a component (F), and a red circle around a component (G). A red arrow points to the text 'Lab 4.5'.

The top toolbar includes: File, Edit, Image, Share, View, Help, Sign In, Favorites, Arrow, Text, Callout, Shape, Stamp, Fill, Move, Step, More, Undo, Redo, Copy All, and Share.

The right sidebar shows 'Quick Styles' with a 'Theme' dropdown set to 'Basic'. Below this are 'Tool Properties' for 'Fill', 'Text Color', 'Shape', and 'Shadow'. The 'Fill' tool is currently selected, showing a blue fill color. The 'Opacity' slider is set to 100. The 'Type' dropdown is set to 'A... B... C...'. At the bottom of the sidebar are 'Effects' and 'Properties' buttons.

The bottom toolbar includes: Recent, Tag, 100% zoom, 1493 x 621px resolution, and a 'Recent' section showing a list of captured images.

Shows recently captured images

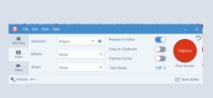
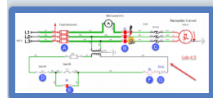

TechSmith Snagit Editor Library



File Edit Image Share View Help Snagit Editor Sign In

Editor Capture

Type to search

January

Name	Size	Date	Modified	Type	Dimensions	Tags
------	------	------	----------	------	------------	------

User can go to any Month & Day for images

- ▶ February 200
- ▶ March 249
- ▶ April 202
- ▶ May 114
- ▶ June 180
- ▶ July 180
- ▶ August 180
- ▶ September 180
- ▶ October 371
- ▶ November 220
- ▶ December 246
- ▶ 2021 350
- ▶ January 185
- ▶ February 84
- ▶ March 81
- ▶ Applications

<p>Jan 28, 2021 2:00:44 PM</p>	<p>Jan 28, 2021 2:00:25 PM</p>	<p>Jan 28, 2021 1:24:29 PM</p>	<p>Jan 28, 2021 1:24:09 PM</p>	<p>Jan 28, 2021 1:12:06 PM</p>
<p>Jan 28, 2021 1:04:18 PM</p>	<p>Jan 28, 2021 1:03:49 PM</p>	<p>Jan 28, 2021 12:57:51 PM</p>	<p>Jan 28, 2021 12:53:41 PM</p>	<p>Jan 28, 2021 11:30:04 AM</p>
<p>Jan 28, 2021 11:29:43 AM</p>	<p>Jan 28, 2021 11:22:08 AM</p>	<p>Jan 28, 2021 11:19:30 AM</p>	<p>Jan 28, 2021 11:19:15 AM</p>	<p>Jan 28, 2021 11:17:33 AM</p>
<p>Jan 28, 2021 11:15:38 AM</p>	<p>Jan 28, 2021 11:07:28 AM</p>	<p>Jan 28, 2021 11:06:39 AM</p>	<p>Jan 28, 2021 10:56:42 AM</p>	<p>Jan 28, 2021 10:50:20 AM</p>
<p>Jan 28, 2021 11:15:38 AM</p>	<p>Jan 28, 2021 11:07:28 AM</p>	<p>Jan 28, 2021 11:06:39 AM</p>	<p>Jan 28, 2021 10:56:42 AM</p>	<p>Jan 28, 2021 10:50:20 AM</p>

- ▶ Adobe Acrobat Reader DC 4
- ▶ Camtasia Recorder 2019 2
- ▶ Component of the Logix D 1
- ▶ Component of the RSLogix 3
- ▶ Google Chrome 1432
- ▶ Internet Explorer 25
- ▶ Microsoft Excel 51
- ▶ Microsoft PowerPoint 651

Creating a PDF Focused Learning Object:



Proximity Sensors/Switches:



Commercial proximity sensor/switches

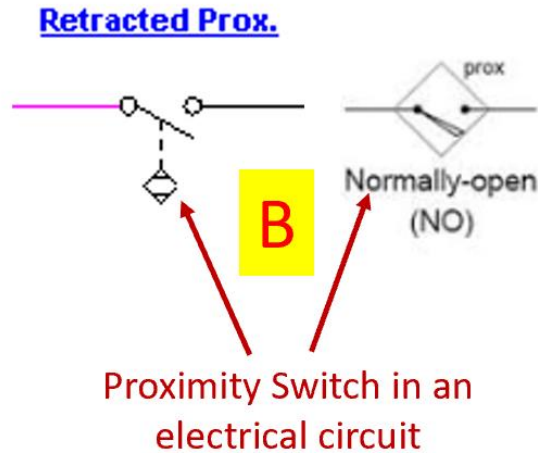

Proximity Switch in an electrical circuit

Proximity switches are devices that sense a part without touching it. A limit switch will touch a part, but a proximity switch senses it. The confusing part of this is that there is one symbol for a pneumatic circuit, and a different symbol for an electrical circuit. The reality is that these are the same device. In graphic A, two proximity switches are shown. They have the sensor on the head (blue part) and the switch internally.

Graphic B shows the two different electrical symbols for proximity switches.

Graphic C shows a magnetic sensor that senses a magnet that is built into the piston of the cylinder. When the cylinder is fully extended, the proximity switch will actuate. Graphic D shows something very similar with a graphic from Automation Studio. Notice that there are two symbols for the proximity sensor on the pneumatic print.

Proximity sensor mounted on a cylinder, sensing a magnet on the piston

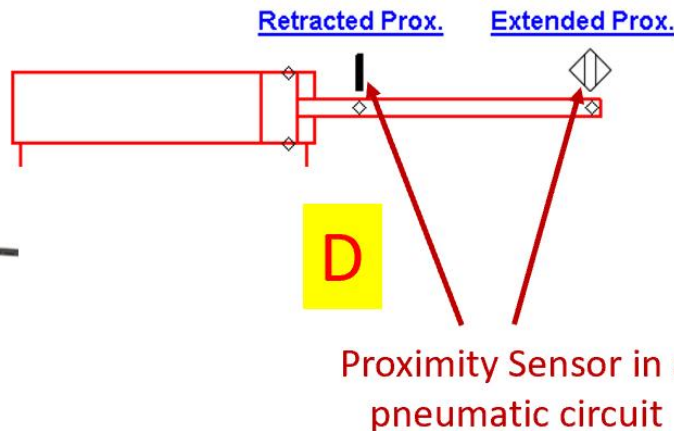
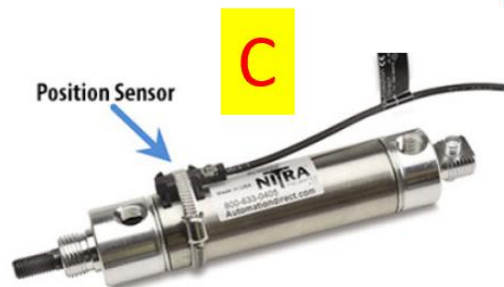

Proximity Sensor in a pneumatic circuit

There are two types of proximity sensor: inductive and capacitive. An inductive senses metal, and a capacitive senses non-metals.

Creating a PDF Focused Learning Object:

Electrical circuit operation:

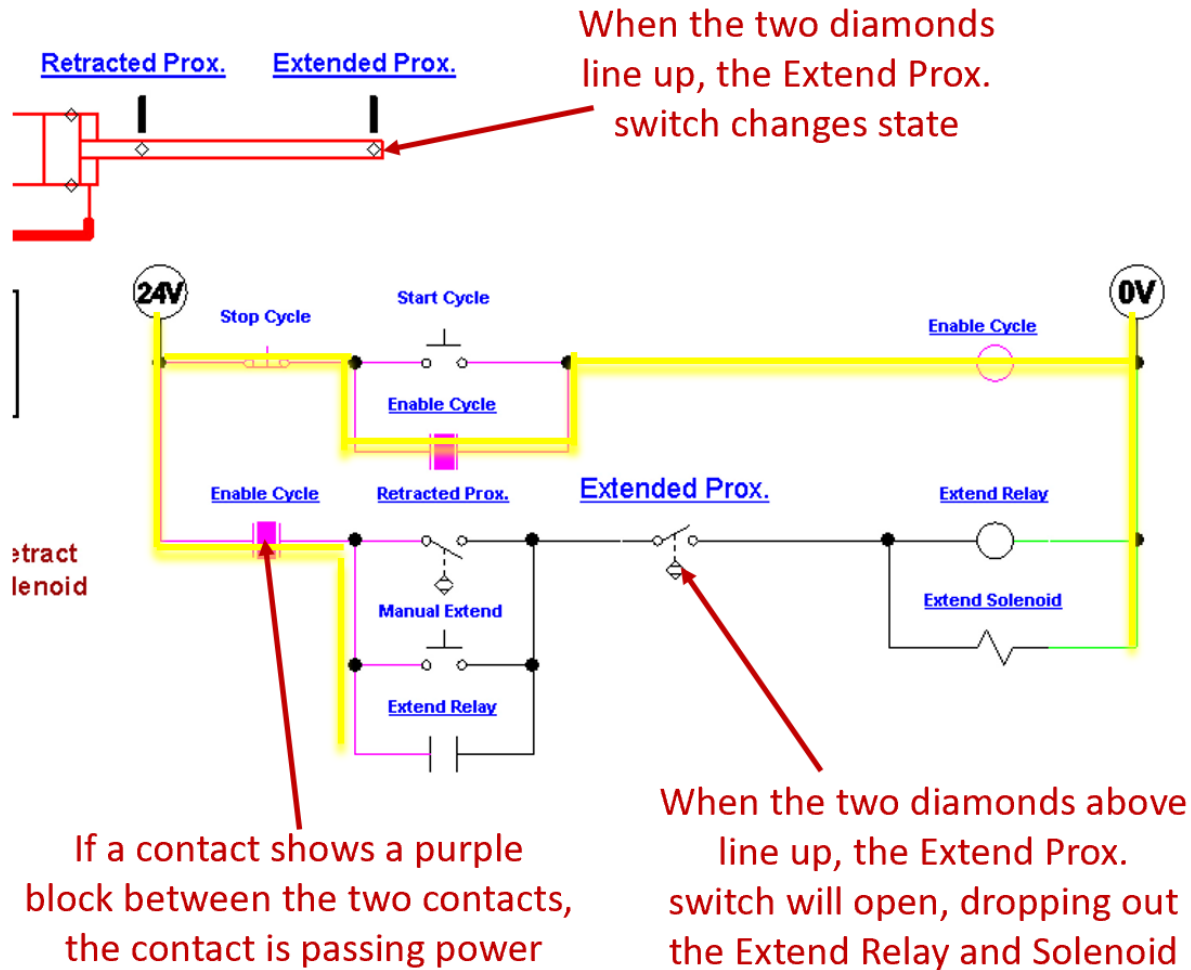

This graphic will give a further in depth explanation of the electrical circuit.

This slide shows that the cylinder rod is fully extended, which actuated the Extend Prox switch. This will open the switch in the last rung of the electrical circuit, which will in turn drop out the Extend Relay and Extend Solenoid coils. This will cause the 5/2 valve to shift back to the default position (due to the spring return), which will start retracting the cylinder.



TechSmith Camtasia Recorder

This software is used to capture the screen of the computer, as well as the voice of the faculty that is creating the video. This can be used to create a video on how to use software that a student will have to learn to use. Camtasia recorder can also be used to do a voice over PowerPoint video, using a stylus on the computer screen, or on a Wacom Tablet to annotate on the screen.

F9 Starts the Recording, and can be used to pause the recording

F10 is used to stop the recording, then it automatically starts Camtasia 2019 (Producer) with the recording

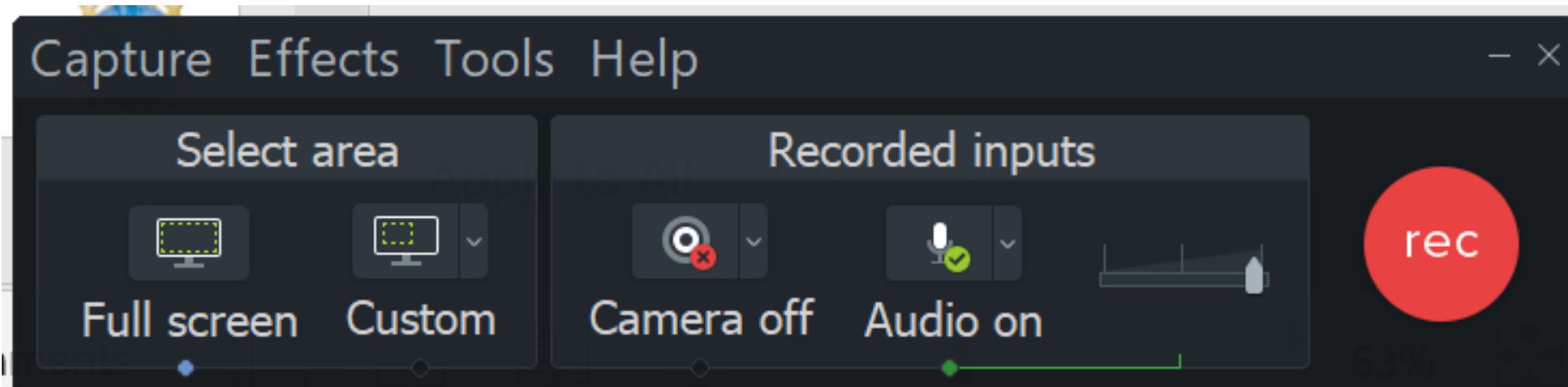

TechSmith Camtasia Producer

Camtasia (Producer) is used to add effects to an MP4 video, edit (or splice) videos, and most of all, to compress the video into a smaller file that can be uploaded to YouTube, or loaded into an LMS for students to download. A smaller file in the LMS minimizes delays for the student, and smaller files take less time for YouTube videos.

The screenshot displays the TechSmith Camtasia Producer interface. The top menu bar includes File, Edit, Modify, View, Share, and Help. The main workspace is divided into several sections:

- Record:** A top bar with a red record button, a play button, a hand icon, a zoom level of 100%, and a Share button.
- Media Bin:** A central area containing two video thumbnails. One is labeled "20_0609_Video..." and the other is "Piping and Instru...". A yellow arrow points from the text "Multiple Videos for Editing" to the "Piping and Instru..." thumbnail.
- Canvas:** The main editing area showing a "Piping and Instrumentation Diagrams" video. The diagram includes components like a Heat exchanger, Steam in, Steam out, Product in, and a Generator. A text box on the right says "Click an object on the timeline or canvas to show its Properties."
- Timeline:** A horizontal axis at the bottom showing video duration from 0:00:00:00 to 0:01:30:00. A yellow arrow points from the text "Video Timeline and Audio Track" to the timeline. Below the timeline is an audio waveform for "Track 1" labeled "Piping and Instrumentation".
- Left Sidebar:** A vertical menu with options: Record, Media, Library, Annotations, Transitions, Behaviors, Animations, and Cursor Effects.
- Right Sidebar:** A vertical menu with options: Sign In, a close button, a download button, and a Share button.



Three types of Video Learning Objects:

Created with a camera:
(Example: How to do something in the lab)



 **Camtasia Producer 2019**

[Explaining 5/2 Valves.MP4](#)

Computer Screen CAM:
(Example: How to use CAD or PLC Software)





 **Camtasia 2019 Recorder**
 **Camtasia Producer 2019**

[Moving RSLinx in Virtual Backplane.MP4](#)

Voice Over PowerPoint:
(Example: Explaining the symbols on a schematic)



 **Camtasia 2019 Recorder**
 **Camtasia Producer 2019**

[Explanation of Lab 6.2 circuit.MP4](#)

Load the MP4 into the LMS for students to download and view:

OR

Upload the MP4 to YouTube, then insert Link into the LMS for students to view:

****Camtasia Producer compresses the MP4 to a smaller file size, making uploading and downloading more efficient.**



Informational Learning Objects (PDFs)

Informational PDF, which are sometimes termed Targeted Learning Objects are usually created in either Word or PPT. The examples I have are with PPT. These will many times have a graphic, then an explanation.

Here are a few examples of Informational Learning Objects:

[IND134 Module 5 Intro to Electrical circuits 050318](#)

[IND223 Module 2 Motor Branch Circuits ver B](#)

[IND220 Module 7 VFDs Basics](#)



Instructional Videos:

Camtasia will be used to create instructional videos. If Camtasia Recorder is started, I can start a video of my screen and add voice and even annotation to the video. The videos are then produced in Camtasia 2019, then saved as an MP4 file. Camtasia condenses the video. The video is then loaded onto a YouTube channel, then the YouTube link is put into the LMS.

[IND134 Lab 4.1 Auto Return circuit in lab with print overlays 3](#)

[IND220 Explanation of Lab 2.3 Circuit 1 082420](#)

[IND220 Explanation of Lab 3.3 Circuit 1 091620](#)



Annotating on the Screen in Camtasia

WACOM is a company that makes a digitizing tablet that connects to the computer via USB or Bluetooth. The tablet allows the user to draw on the screen of a computer that is not a touchscreen. Many touchscreen computers come with a stylus for drawing on the screen, instead of using a Wacom Tablet.

Purchase & register your Intuos Pro to receive creative software

Software offer available in Americas only



Annotating on the Screen in Camtasia Recorder



The WACOM tablet, or stylus on a touchscreen will allow the Faculty to draw on a picture, similar to drawing on a whiteboard.

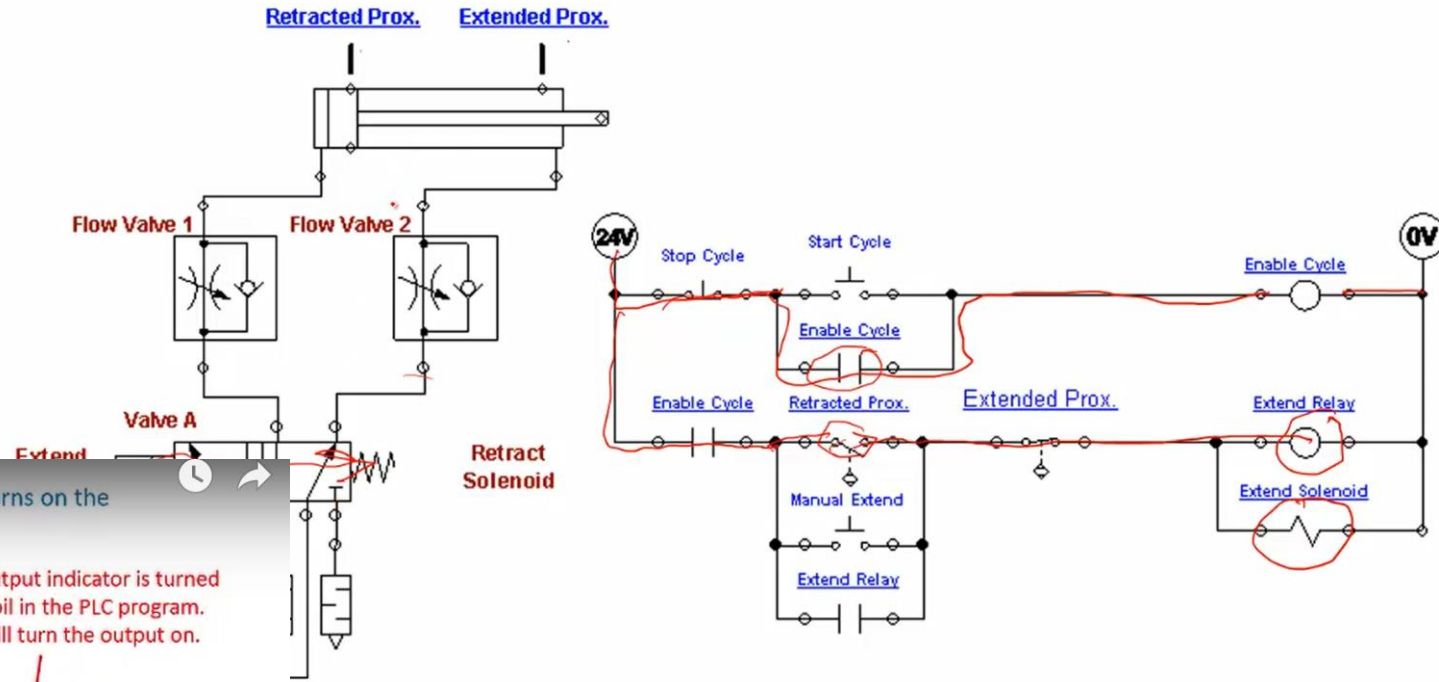

16 0222 Intro to PLC short part 1 conceptually from the left to the right.

-Inputs are actuated, which turns on the input status light. The PLC analyzes these signals and turns on the output status lights, which turns on the output devices.

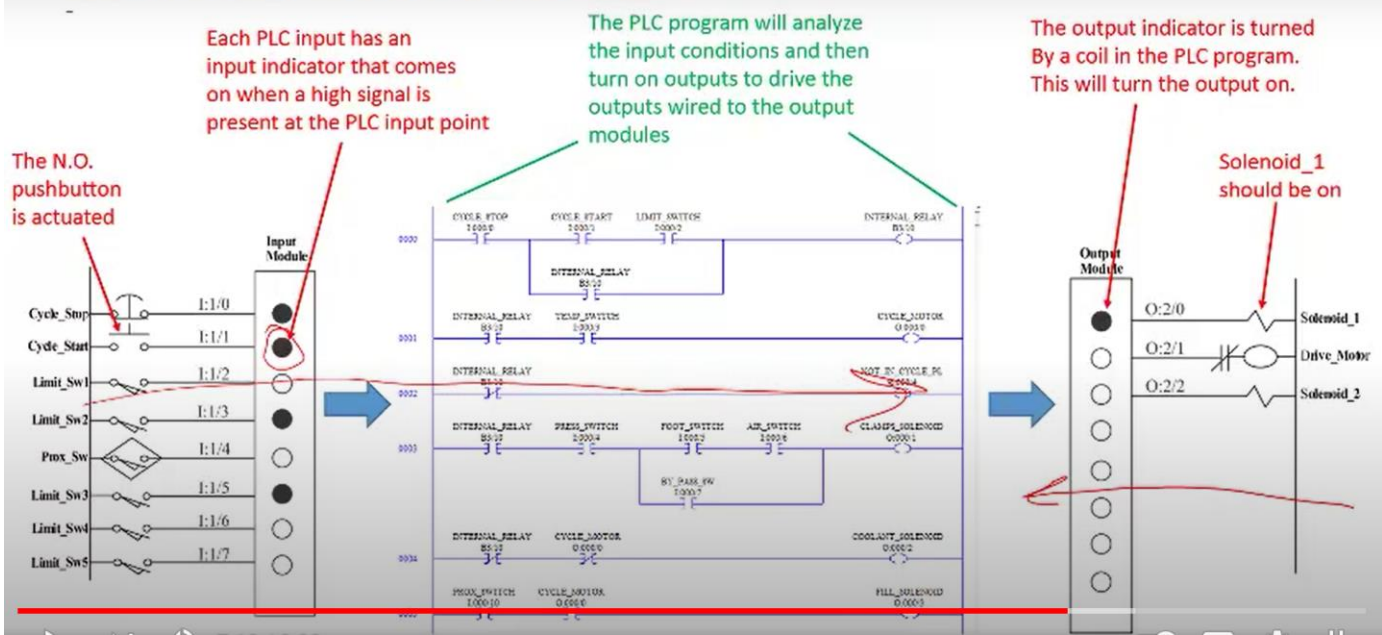



Video Links in the LMS:

Video Links (or MP4 videos) are loaded into your LMS so students can view the videos from the computer or portable devices. Where do these links originate?

1. Faculty finds a video on YouTube for students to view
2. Faculty finds a video on Skillscommons.org or Vimeo
3. Faculty creates their own video, then loads it into YouTube, or loads the MP4 into the LMS



Storing Videos on YouTube:

If you create your own videos, you may decide to upload them to YouTube, and use the link in the LMS for students to view.

1. Your IT department should create a YouTube channel for you
2. Always have a way of documenting your video uploads
3. A Gmail account can give you a YouTube channel
4. Updating captions are important for ADA compliancy



Linking to YouTube Videos:

YouTube is a great source for finding videos for the students to view, but also as a place for the faculty to store their videos. A link from the video within the LMS, will allow the students to stream the video to their computer or portable devices. Each video on YouTube has a unique Video Identifier.

YouTube Video: T. Wylie, Video on setting RSLinx and FTLinx on virtual backplane, 12/4/20

<https://youtu.be/POSmMFjfajg>

Video Identifier

YouTube Video URL that will have the video start at a specific time:

<https://www.youtube.com/watch?v=1K0YF1foxVk&t=3m10s>

YouTube Video URL that will have the video start at a specific time, and end at a specific time:

<https://www.youtube.com/embed/SMsYHbtYnK8?start=50&end=60>



Demonstration on Creating Objects:

1. Capturing with Snagit
2. An Informational PDF
3. Recording a video with Camtasia Recorder
3. Voice over PowerPoint Video
4. Editing a video with Camtasia
5. Adding a video to another video
6. Uploading to YouTube



How-To Videos for Session 2:

YouTube Video: T. Wylie, Video on Finding OER Videos and Simulations 042221
<https://youtu.be/uo934NaFoxs>

YouTube Video: T. Wylie, Video Searching for OER in Skillscommons 042221
<https://youtu.be/ep4Erjg46bs>

YouTube Video: T. Wylie, How to produce an MP4 with camtasia producer 042421
<https://youtu.be/2iZCLMnSDhk>

YouTube Video: T. Wylie, 21_0425_Example of a voice over PPT video
<https://youtu.be/KXi-iqFUohU>

YouTube Video: T. Wylie, 21_0425_Creating a video and uploading to Youtube
<https://youtu.be/ZG4jEiF2Wgw>

YouTube Video: T. Wylie, 21_0425_Edit closed captions in Youtube
<https://youtu.be/eNdX1RrBf5U>



The End of the Presentation

Please email the presenter with
Any questions you may have, as
well as any feedback on the session
(twylie@northweststate.edu)