

5

Final Control Elements

Objectives:

Students will be able to:

- Describe the function, construction and operation of a I/P converter
- Explain the function and importance of control loop component calibration
- Describe how to calibrate an I/P converter using a loop calibrator
- Differentiate between the two types of proportional valves
- Outline the operation of a spring-and-diaphragm actuated control valve
- Identify two types of spring-and-diaphragm actuated control valve configurations
- Describe how to adjust the spring of a diaphragm actuator proportional valve

Orienting Questions:

- What is an I/P converter and what is its function in a control loop?
- What is the function of I/P calibration?
- How does a spring-and-diaphragm actuated control valve work?

Terms to Know

Final control element	I/P Converter
Spring-and-diaphragm actuator	Reverse acting valve
Air-to-close valve	Actuator
Air-to-open valve	Electric actuator
Direct acting valve	Linear equation



INTRODUCTION

INTRO Click on Button to see and hear an introduction to this module

TEXT Click on Button to read text to above introduction

CURRENT-TO-PRESSURE (I/P) CONVERTER

Let's consider the following situation—you have an electronic controller with an output that is an electrical signal (4-20 mA), and you want to have it control a new air-actuated control valve with an input that is a pneumatic signal (3-15 psi). As we saw in Module 4, individual components of a process control system have to be able to “talk” to each other and your two devices don't “understand” each other (see Figure 1 below).

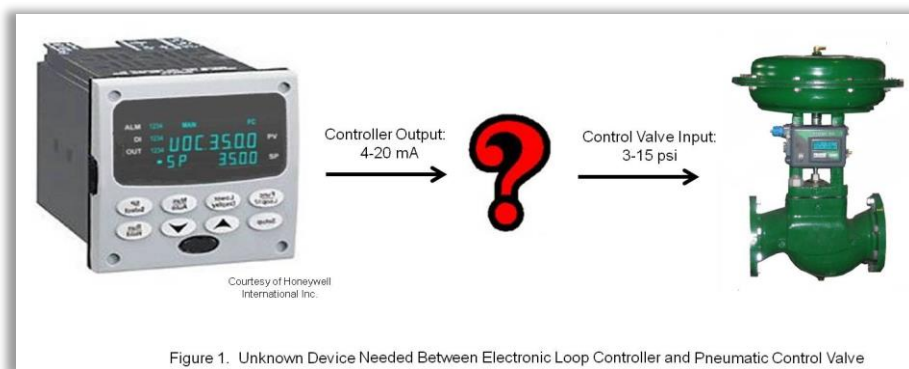

If someone came up to you speaking a foreign language that you didn't understand, you would need a translator to communicate. For the situation in Figure 1, we have a device that "translates": it is the current to pressure (**I/P**) **converter**, which converts an analog electrical signal (typically 4 to 20 mA) to a pneumatic output (typically 3 to 15 psi). The inputs and outputs follow a linear function (recall Figure 7 in the previous module on Loop Controllers). Together the I/P converter and the control valve make a functional **final control element** when paired with an analog controller (see Figure 2).

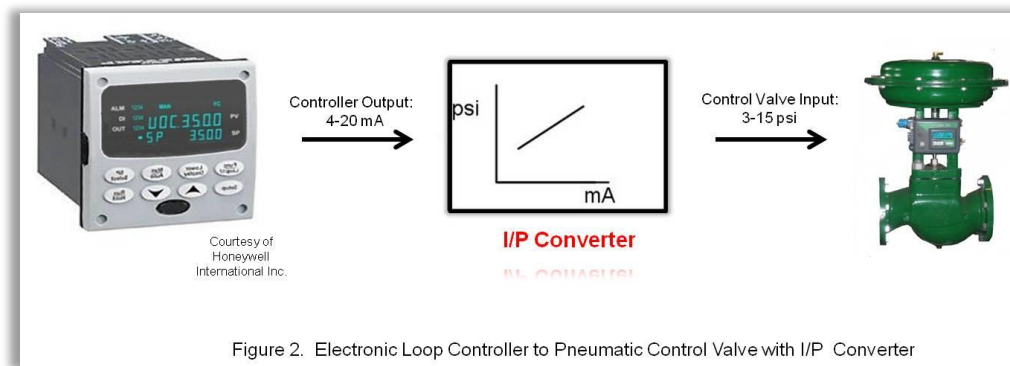

Despite coming in many different designs and appearances, I/P converters all function in the same way; namely, they accept an analog electric current (DC) and pressurized air (supply) signal inputs, and output a variable air pressure signal proportional to the electric current input. They consist of two parts: the electronic and the pneumatic components. The electronic part consists of an electronic card that is used to process the current input signal and convert it to a pneumatic signal. The pneumatic part consists of a relay that transmits and amplifies the pneumatic signal output from the I/P converter. They are typically built with an outside metal enclosure to protect the internal mechanisms. To see the latest models of I/P converters, simply consult the internet.

A schematic diagram (Figure 3) illustrates the important external components of the I/P converter. Its connections include air input (air supply, typically 20 psi), air output (to the control valve) and the electrical signal (input from the controller). In addition, zero and span screws are available for calibration adjustments. The zero adjustment sets the desired output (typically 3 psi) to the minimum input current (typically 4 mA). The span adjustment is the difference between the minimum and maximum values of the input (also called the range) and sets the output (typically 15 psi) when the input is at a maximum value (typically 20 mA). This I/P converter also shows a pressure gauge to indicate the pressure output. When a pressure gauge is not integral to the I/P converter, a separate gauge needs to be attached for pressure reading.

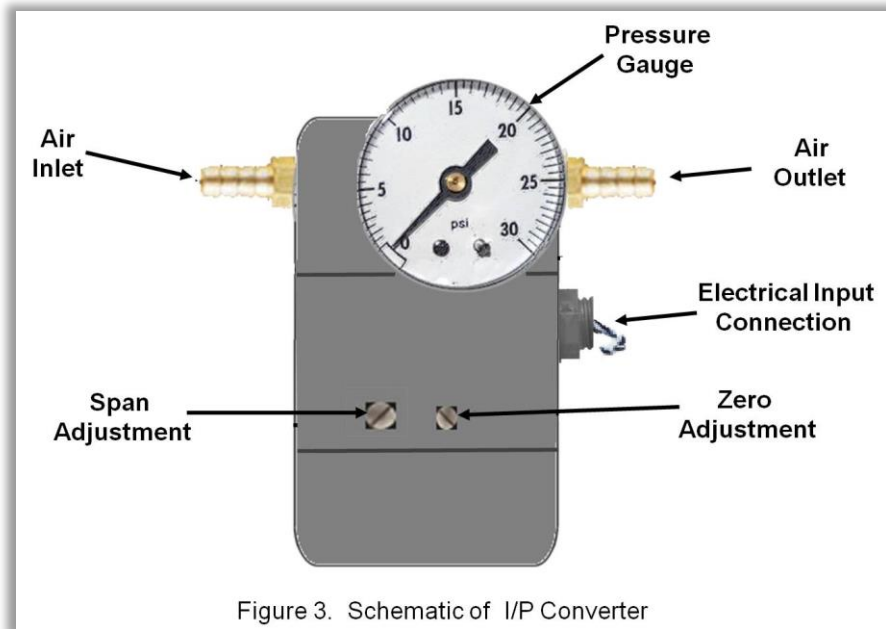
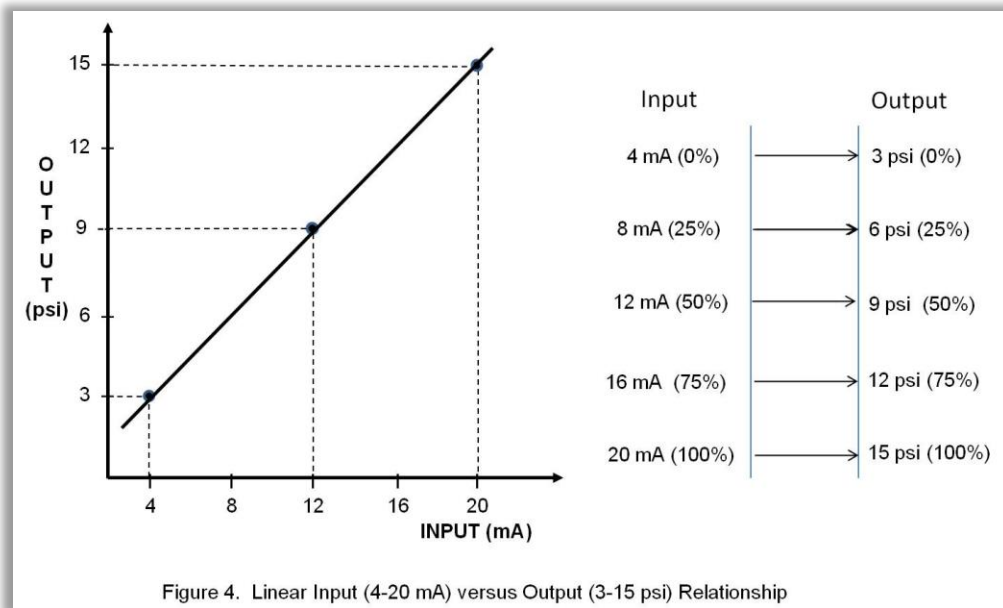

Figure 3. Schematic of I/P Converter

As stated above, the relationship between the input signal and the output signal is linear. Calibration is accomplished to make sure that this linear relationship is in fact obtained. This concept is **extremely** important to understand. It is the job of the I/P converter to simply change signal from an analog electrical signal to a pneumatic signal and **NOT** alter any information about the process variable. This calibration procedure sets the range in order to properly represent the desired process variable after the signal has been outputted from the I/P converter. In the case of the standard input of 4-20 mA and output of 3-15 psi, this means that

4 mA input must translate to a 3 psi output
and
20 mA input must translate to a 15 psi output

In addition, all values of input between the minimum and maximum values must correspond to values of output based on the mathematical function that the device is designed to impart. In the case of the I/P converter this mathematical function is **linear**. For 4-20 mA input and 3-15 psi output ranges, the relationship shown in Figure 4 should be the result.



Calibration of the I/P converter (to make sure that the relationship in Figure 4 holds) involves detaching the controller output from the I/P converter input and replacing it with a calibrated sourcing current. The calibrated source, called a loop calibrator, is expressly made for this function and is widely used and available for purchase. It is a 4-20 mA current source and a meter in one and is connected to the I/P converter as shown in Figure 5.

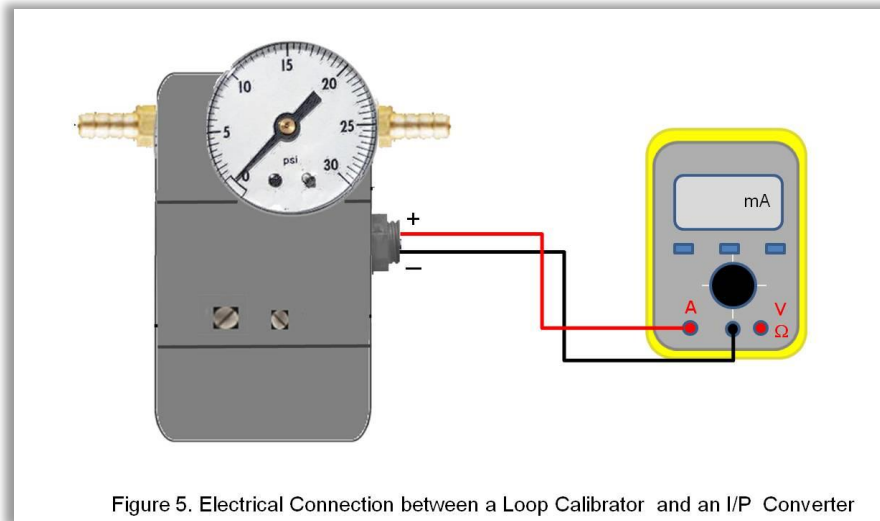

Figure 5. Electrical Connection between a Loop Calibrator and an I/P Converter

The calibration procedure, also called the zero-and-span method involves the following steps:

1. Connect a 4-20 milliamp current source (e.g., loop calibrator) to the I/P converter input.
2. Apply a 4 mA signal (0%) and record the output.
3. Turn the zero adjustment screw (using a small slotted screwdriver) until the output pressure reads the minimum pressure (3 psi).
4. Apply a 20 mA signal (100%) and if reading is not 15 psi (100%) at the output, then turn the span adjustment until the pressure gauge reads 15 psi.
5. Apply a 4mA signal and check that the output is still 3 psi (span adjustment may have altered the zero). If it has changed, adjust as required.
6. Check the span again at 20mA and repeat Steps 6 and 7 until the I/P converter reads 3 psi at 4 mA and 15 psi at 20 mA repeatedly.
7. Next check the linearity by injecting signals for 0, 25, 50, 75 & 100%. The output should read as follows:
 - 0% (4mA) 3psi
 - 25% (8mA) 6psi
 - 50% (12mA) 9psi
 - 75% (16mA) 12psi
 - 100% (20mA) 15psi

This calibration procedure (the zero-and-span method) is performed on new and in service devices (including other linear proportional devices in the control loop) to make sure they are functioning as required.



Click on Button to see a short tutorial on **Standard Calibration Procedure** by wisc-online.com. Be sure to do the review at end

In Figure 4 above, the I/P converter is direct acting (when the current input increases, so does the output pressure). In reverse acting I/P converters, the output pressure decreases as the input current increases.

1

Q&A

Draw the input versus output graph (comparable to Figure 4) for the reverse acting I/P converter in the 4-20 mA and 3-15 psi ranges.

The P&ID symbol for the I/P converter is composed of two symbols, the usual instrument tag with a smaller rectangle in the upper right-hand corner containing the letters I/P. This small rectangle indicates that the device performs a mathematical function. This is shown in Figure 6 for an I/P converter that is part of a flow control loop.

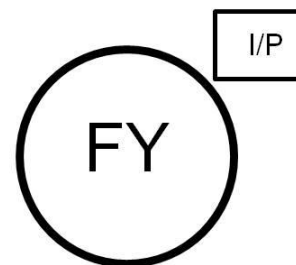

Figure 6 P&ID Symbol for an I/P Converter used for Flow Control



2 Q&A

Before we leave the discussion on I/P converters, let's have a look at the P&ID diagram for the devices shown in Figure 2. Let's assume the electronic controller is used for flow control and has indicating capability. The controller is located on the front panel of the main control room in Area 31 and is part of loop 121. The I/P converter is located in the field. The pneumatic spring-and-diaphragm control valve (with a globe valve body) in the figure has a positioner.

Draw the P&ID symbols for the three devices including the lines that connect them.

Let's say that you meticulously followed the zero-and-span method of calibration described above and then found out that your loop calibrator and/or your pressure gauge were not reading accurately. Obviously, if this is the case, your zero-and-span calibration is **not** accurate either. In industry, devices like pressure gauges and loop calibrators are checked against certified standards from the National Institute of Standards & Technology (NIST) on a regularly scheduled basis to ensure the accuracy of devices being used to calibrate other devices. Slight errors in one or two gauges or meters could result in errors being compounded and magnified and the result could be either poor product quality or safety problems, or both. This need for accuracy cannot be stressed enough, nor the process technician's role in performing the calibration correctly and with the detail required.

PNEUMATIC CONTROL VALVES

Now that we have solved our input/output communication problem by incorporating an I/P converter in our control loop, let's move on to the other final control element; namely, the control valve. While the selection of valve body type is very important for a given process condition, we will be concentrating on the valve **actuator**, specifically the **pneumatic spring-and-diaphragm actuator**, for the rest of this module. As seen in the introduction of this module and in Module 3 (Piping and Instrumentation Diagrams), control valves can be actuated by other sources of energy (electrical analog, hydraulic, and electrical binary). Details of these types will not be discussed in this module. All figures in the rest of this

module will be drawn with a globe valve body for uniformity and no relationship between valve stem opening and flow rate is implied.

Pneumatic actuators use air pressure pushing against either a flexible diaphragm or a piston to move a valve mechanism. For the rest of the discussion in this module, we will be concentrating on the specific pneumatic control valve called the spring-and-diaphragm actuated control valve. A schematic diagram of a spring-and-diaphragm actuated control valve is given in Figure 7. The three main parts include the actuator, the valve body and the frame to hold them together, called the yoke. The actuator is located at the top of the figure and contains the mechanism for moving the valve stem up and down. A rubber diaphragm separates the actuator housing into two air chambers with the upper chamber receiving air inlet supply through an opening in the top of the housing. The lower chamber contains the spring that exerts force upward. The valve stem slides up (decreasing air pressure) or down (increasing air pressure). The moving parts in this arrangement are the valve stem and the diaphragm membrane. The spring compresses and decompresses.

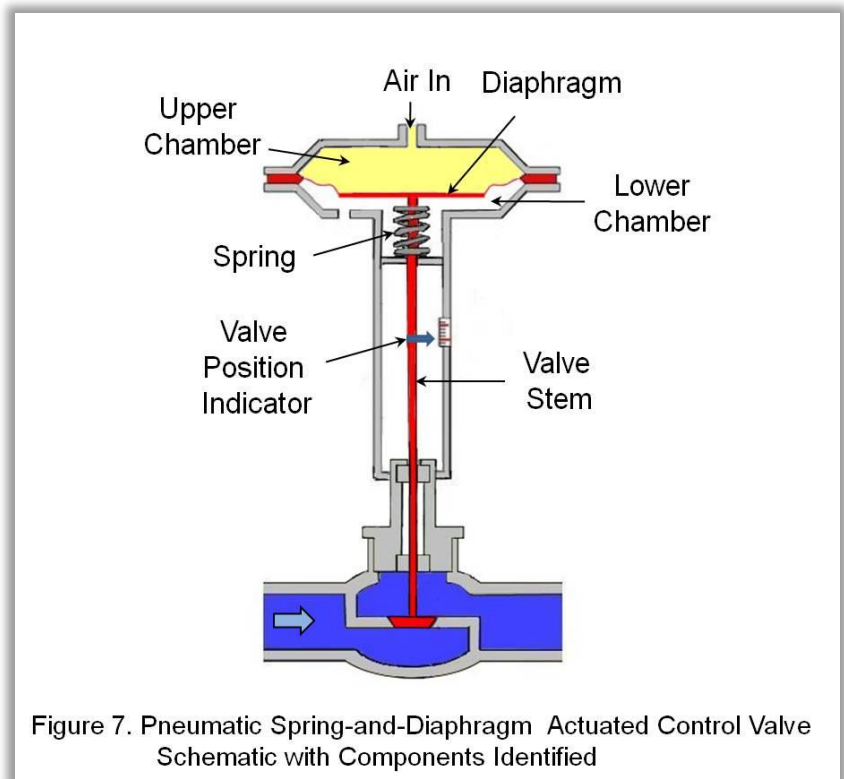
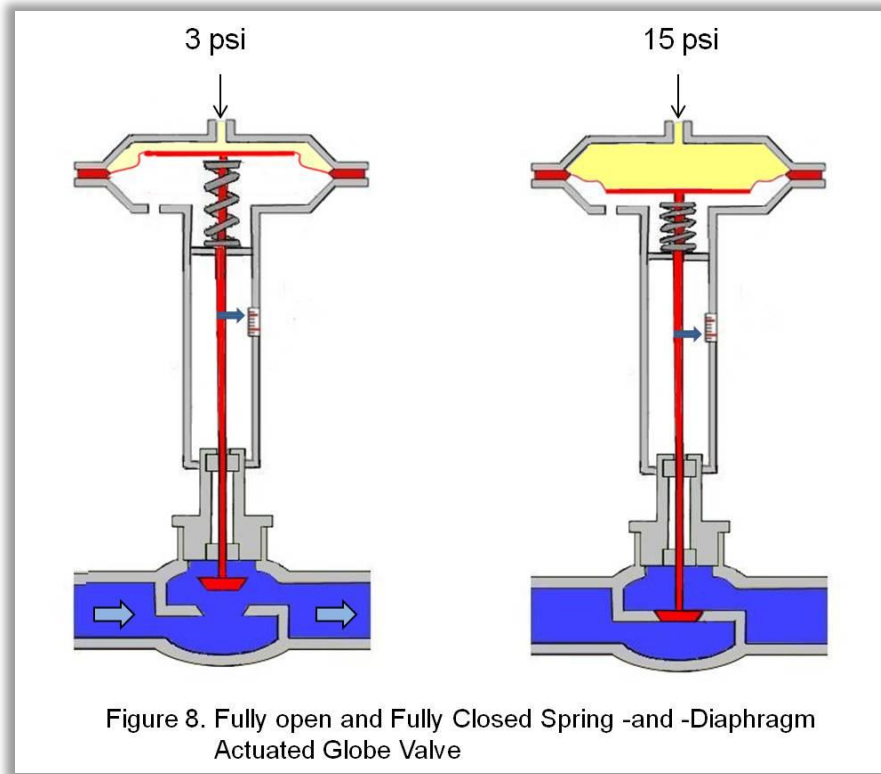

Figure 7. Pneumatic Spring-and-Diaphragm Actuated Control Valve Schematic with Components Identified

A valve position indicator, attached to the valve stem, is also given to indicate valve stem travel. As described earlier, the valve body is a globe valve, where the valve disc fits into the valve seat when the valve is fully closed (the state shown in the figure). For valves such as a butterfly valve (a rotary-type valve), opening and closing the valve requires an actuator design that uses a rotary spring instead of the linear spring shown in the figure above.

A pneumatic spring-and-diaphragm actuated control valve designed for 3-15 psi operation will have the fully opened state with 3 psi inlet air pressure and the fully closed state for 15 psi. These two final states are shown in Figure 8 below:



The downward pressure exerted by 3 psi air is insufficient to compress the spring, and the stem remains in the fully opened state. As the air pressure is increased, the spring compresses and the valve stem slides down. At 15 psi, the valve stem is positioned so that the valve disc is fully in the valve seat (fully closed). Note the location of the valve position indicator (attached to the valve stem) for the fully open and fully closed positions. If air inlet pressure is held constant at some value between 3 psi and 15 psi, the valve will stay at an intermediate position between fully open and fully closed. Therefore, the valve stem/disc can be positioned anywhere between fully open and fully closed in response to changes in air inlet pressure.

3 Q&A

What happens to the control valve in Figure 8 when the air supply to the actuator is lost (fails)?

For the devices in Figures 7 and 8, the failure mode is called “fail open” and the valve action is called “**air-to-close**”. Just as we saw earlier with loop controllers and I/P converters, this type of actuator is called **direct-acting** because an increase in input signal (the air pressure) results in an increase in the output signal (sliding the valve stem downward).



Click on Button to see a short tutorial on **Spring-and-Diaphragm Actuator** by wisc-online.com.

If increasing air pressure to the actuator causes the valve stem to move upward, then the actuator is called **reverse-acting**. The reverse-acting actuator in Figure 9 shows that increasing air pressure to the lower chamber of the actuator results in the valve stem going upward.



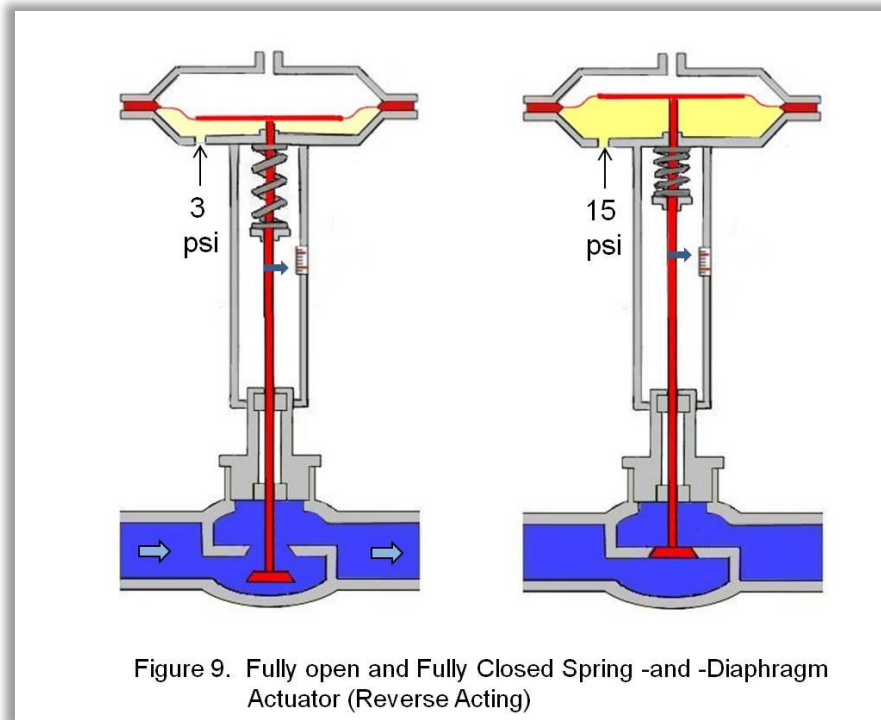

As with most engineered products, the design for the spring-and-diaphragm actuator in Figure 9 is not universal. Some reverse-acting actuators are designed with the spring above the diaphragm. It is important to remember which way you want the valve stem to go when air pressure is increased, and not the particular design, when ordering a new actuator.

4 Q&A

What is the difference between the fully open positions of the valves in Figures 7 versus 9?

Just like the loop controller, I/P converter and the control valve actuator, the valve can also be direct and reverse acting. A direct-acting valve closes when the valve stem is pushed down and opens when the valve stem is pushed up. The direct and reverse acting valves are depicted in Figure 10.

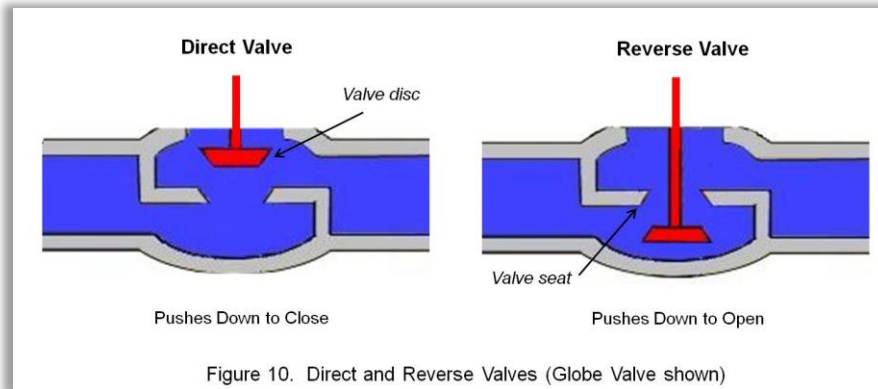

The direct valve open position has the valve disc above the valve seat and the reverse valve open position is below the valve seat.



TUTORIAL

Click on Button to see a short tutorial on Air-to-Open/Air-to-Close Valves by wisc-online.com. Be sure to do the review at end.

Combinations of direct and reverse-acting actuators and direct and reverse-acting valves create four couplings as illustrated in Figure 11, where all the actuators are shown with minimal air pressure.



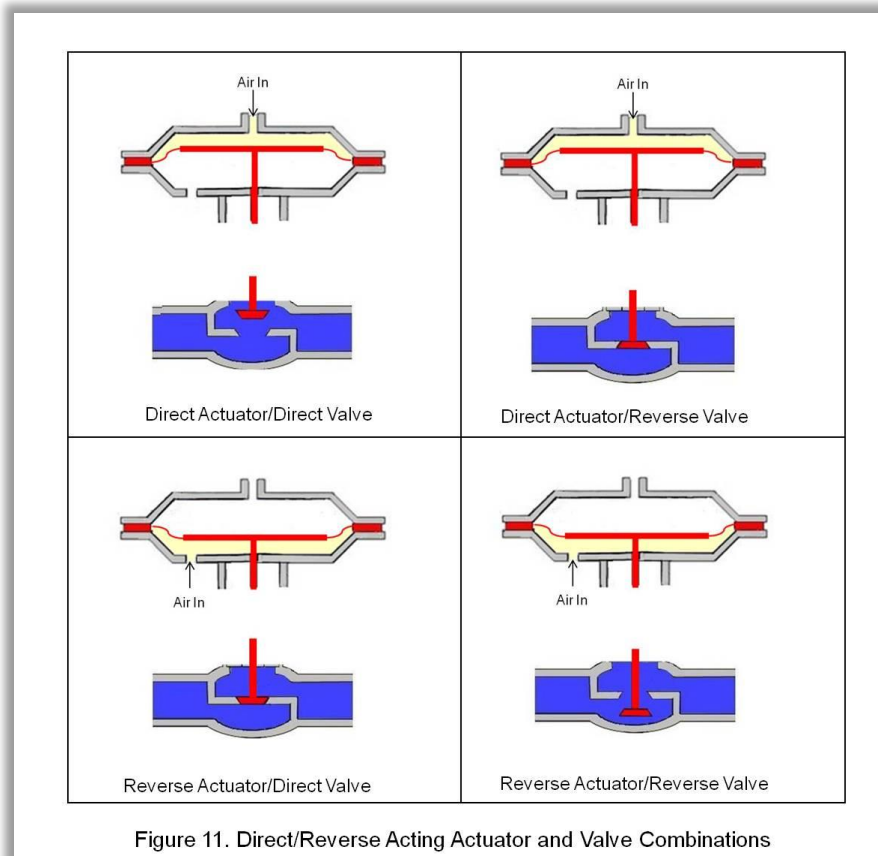

The choice between direct-acting and reverse-acting pneumatic actuator/valve action depends on the position to which the valve should revert in the event of air supply failure. Should the valve be closed (fail closed) or open (fail open)? This choice depends upon the nature of the application and safety requirements. For example, steam valves should close on air failure, while cooling valves should open on air failure.

5 Q&A

Complete the table for the valve action and failure mode (consult Figure 11) for each combination of valve and actuator type.

valve	actuator	valve action	failure mode
direct	direct	air to close	fail open
reverse	reverse	?	?
reverse	direct	?	?
direct	reverse	?	?

Although our definition of direct and reverse are consistent, some manufacturers of control valves may vary on how they specify direct versus reverse action. For example, a manufacturer may call all air-to-close valves as direct acting even if the actuator and valve combination are both reverse.

Let's look at an **air-to-open** control valve. When the control valve is calibrated (or 'bench set'), it is adjusted so that an air pressure of 3 psi will be insufficient to overcome the resistance of the spring and move the valve stem, so the valve will be fully closed. As the air pressure is increased to 15 psi, the valve stem moves and linearly opens the valve. At 15 psi, it is fully open.

6

Q&A

Graph this relationship if we assume that the relationship between air pressure (input) and valve opening (output) is linear. Range is 3-15 psi and 0-100%.

If air-to-close defines a direct actuator, then is the actuator you graphed direct or reverse actioned?

In service, this bench set calibration may not match your conditions, e.g., 3 psi \neq fully closed valve. An adjustment needs to be made on the spring-and-diaphragm actuator called a spring adjustment. This spring adjustment involves turning an adjusting nut to change the spring compression (sometimes called spring preload). This effectively changes the spring force acting against the air pressure and therefore changes the air pressure necessary to move the valve stem a given distance. Instructions for how to perform a spring adjustment are given in the video below.





Click on Button to see a short demonstration on spring adjustment on a spring-and-diaphragm actuator.

SUMMARY OF KEY CONCEPTS

The following topics were presented during this lesson:

A. LESSON HIGHLIGHTS

1. Introduction to Final Control Elements
2. Common characteristics of a Current to Pressure (I/P) Converters
3. The principles and operations of a Pneumatic Control Valve.
4. Explanation of final element terms.

SUMMARY STATEMENT

The information presented in this lesson are items that will give the trainee a better understanding of components that make up the Final Control Elements in a Process System. Explanations of component functions and the need for an accurate calibration shows how important it is to properly maintain these components.

LABS

All laboratories require the T5552 Process Control Learning System by Amatrol, water supply, and a compressed air supply.

- Laboratory 1. Connect and operate an I/P converter
- Laboratory 2. Calibrate an I/P converter
- Laboratory 3. Connect and operate a diaphragm actuator proportional valve
- Laboratory 4. Adjust the spring of a diaphragm actuator proportional valve



Requirements for successful lab completion: Lab instructor evaluation of lab performance and completion of laboratory experimental report on introductory process control functions and safety.

TESTING



Click on Button for terms testing and flashcards at quizlet.com

1. The output signal of an I/P converter is
 - a. pressure
 - b. electric analog
 - c. power
 - d. electric binary
2. (Short Answer) In order to properly calibrate an I/P Converter a technician must connect a _____ to the input side of I/P converter.
3. The mathematical relationship between the input and output signal for an I/P converter is
 - a. square root
 - b. linear
 - c. exponential
 - d. summation



4. The span adjustment of the I/P converter sets the
- minimum output current
 - minimum input current
 - maximum input pressure
 - maximum output pressure
5. A reverse acting I/P converter causes the air pressure to _____ on the _____ of valve diaphragm as input electrical signal is increased.
6. The three main parts of the spring-and-diaphragm control valve are the valve body, the yoke, and the _____.
- actuator
 - valve stem
 - valve position indicator
 - I/P converter
7. In a spring-and-diaphragm control valve, air pressure pushes against a _____.
- piston
 - gear
 - valve seat
 - diaphragm
8. In a reverse valve, the open position is.
- above the valve seat
 - below the valve seat
 - held at mid-point
 - held at fail safe



9. For a reverse actuator and a reverse valve, the valve action is _____ and the failure mode is _____.

- a. air to open and fail closed
- b. air to close and fail open
- c. air to open and fail open
- d. air to close and fail closed

10. The spring on a spring-and-diaphragm actuator is adjusted when the valve does not perform in service as defined by the bench set. Adjusting the spring results in a change in the spring's _____.

- a. position
- b. size
- c. tensile strength
- d. compression



ANSWERS TO ACTIVITIES



1.

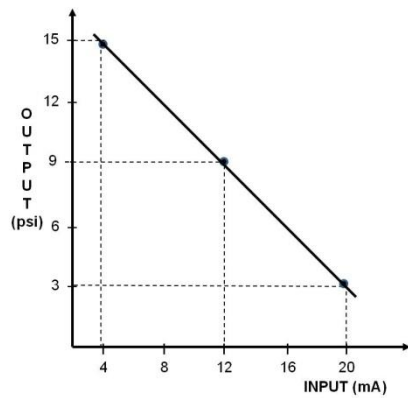

2.

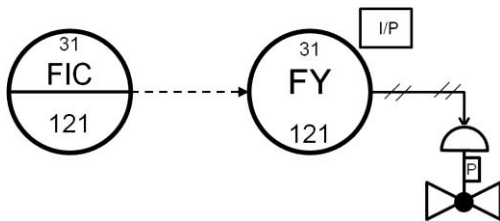

3. valve opens, closed valve

4. In Figure 7, the fully open valve position is above the valve seat and in Figure 9 it is below the valve seat.



5.

valve	actuator	valve action	failure mode
direct	direct	air to close	fail open
reverse	reverse	air to close	fail open
reverse	direct	air to open	fail closed
direct	reverse	air to open	fail closed

6.

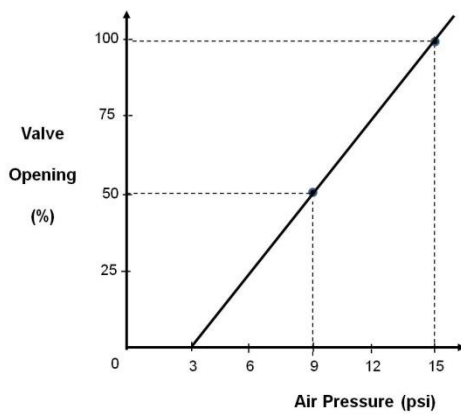

closing on y-axis)

reverse-acting (more obvious if we had graphed % valve

TEST ANSWERS:

1. a. pressure
2. 4 – 20 mA signal
3. b. linear
4. d. maximum output pressure
5. Increase, Bottom

6. a. actuator
7. d. diaphragm
8. b. below the valve seat
9. b. air to close and fail open
10. d. compression

ATTRIBUTION TABLE

Author/s	Title	Source	License
Mary Anton	(1) Unknown Device Needed Between Electronic Loop Controller and Pneumatic Control Valve	http://www.flickr.com/photos/93439252@N04/9524861716	cc-by-nc
Mary Anton	(2) Electronic Loop Controller to Pneumatic Control Valve with I/P Converter	http://www.flickr.com/photos/93439252@N04/9522078073	cc-by-nc
Mary Anton	(3) Schematic of I/P Converter	http://www.flickr.com/photos/93439252@N04/9524861766	cc-by-nc
Mary Anton	(4) Linear Input versus Output Relationship	http://www.flickr.com/photos/93439252@N04/9524861614	cc-by-nc
Mary Anton	(5) Electrical Connection between a Loop Calibrator and an I/P Converter	http://www.flickr.com/photos/93439252@N04/9524861550	cc-by-nc
Mary Anton	(6) P&ID Symbol for an I/P Converter used for Flow Control	http://www.flickr.com/photos/93439252@N04/9524861498	cc-by-nc
Mary Anton	(7) Pneumatic Spring-and_Diaphragm Actuated	http://www.flickr.com/photos/93439252@N04/952	cc-by-nc



	Control Valve Schematic with Components Identified	4861468	
Mary Anton	(8) Fully open and Full Closed Spring-and-Diaphragm Actuated Globe Valve	http://www.flickr.com/photos/93439252@N04/9524861514	cc-by-nc
Mary Anton	(9) Fully open and Fully closed Spring-and-Diaphragm Actuator (Reverse Acting)	http://www.flickr.com/photos/93439252@N04/9524861478	cc-by-nc
Mary Anton	(10) Direct and Reverse Valves	http://www.flickr.com/photos/93439252@N04/9522077655	cc-by-nc
Mary Anton	(11) Direct/Reverse Acting Actuator and Valve Combinations	http://www.flickr.com/photos/93439252@N04/9524861362	cc-by-nc
Synapse Engineering	Wastegate Spring Rate and Spring Pre-Load Explained	http://www.youtube.com/watch?v=LStlqe64m4M	Standard youtube license



This workforce solution was funded by a grant awarded by the U.S. Department of Labor's Employment and Training Administration. The solution was created by the grantee and does not necessarily reflect the official position of the U.S. Department of Labor. The Department of Labor makes no guarantees, warranties, or assurances of any kind, express or implied, with respect to such information, including any information on linked sites, and including, but not limited to accuracy of the information or its completeness, timeliness, usefulness, adequacy, continued availability or ownership.



ASSIST Consortium Curriculum is licensed under a Creative Commons Attribution 3.0 Unported License.

Except where otherwise noted, this work was created by **Mary Anton** and is licensed under the Creative Commons Attribution 3.0 Unported License. To view a copy of this license, visit <http://creativecommons.org/licenses/by/3.0/> or send a letter to Creative Commons, 444 Castro Street, Suite 900, Mountain View, California, 94041, USA.

