

# Overview of the NSF ATE HOME4TECHS Project (2015-2018)

Presented by:

Tom Wylie, PI for HOME4TECHS & SCALE\_UP  
Northwest State CC, Archbold, OH



# HOME4TECHS

## Hands On Maintenance Education 4 TECHnicians



### Problem:

- Curriculum needed realignment to employer needs
- Traditional college schedules no longer works for employers
- Inconsistent skill levels of graduates
- Completion of traditional college certificate/degrees take too long

### Solution:

- Redesign the curriculum to meet employers needs
- Build a **competency-based, hybrid instructional model**
- Require individual skill assessments
- Move the courses' **lecture portion to an online format**
- Utilize technology tools to accelerate learning
- Offer the students a **flexible open-lab schedule**

### Project consists of 3 distinct areas:

#### Curriculum

- Realignment of curriculum
- Competency-based learning
- Hybrid course model
- Modular online eLearning
- Hands-on assessments
- Open lab learning model

#### Technology to accelerate learning

- Virtual machines for each student
- Hands-on hardware simulations
- Student access to software 24/7
- Virtual interactive simulations
- MOOCs

#### Faculty professional development

- Quality matters
- Instructional systems design
- Online course development
- Instructing online courses
- Technical content cross-training
- Learning object development



**Programmable Controller Course**  
Allen Bradley MicroLogix and CompactLogix

**Motors & Controls**  
Allen Bradley PowerFlex 70s and 525s

**Servo & Robotics**  
Fanuc LR Mate 200iD



[northweststate.edu/HOME4TECHS](http://northweststate.edu/HOME4TECHS)



# Overview of the HOME4TECHS Project

- Won in 2015. Ran from 8/1/15 to 7/31/18.
- Amount was approximately \$200K
- Focus was to build a model to convert lecture/lab technical courses to a competency-based/hybrid model
- 3 courses were converted:
  - IND223: Motors & Motor Controls
  - PLC200: Programmable Controller I
  - PLC230: Servo & Robotics

## Overview of the HOME4TECHS Project, cont.

- 3 faculty were PI & Co-PIs
- Assessment model changed everything
- Lecture moved online, scheduled & open lab model
- Project results (2 yrs previous to 2 yrs of the new model):
  - 44% increase in enrollment (of the 3 courses)
  - 10% increase in retention
  - 7% increase in grade level attainment

# Overview of the HOME4TECHS Project

- Why did NSCC pursue funds for this project?
  - New LEAN initiative at NSCC
  - The college had to get the voice of the customer
  - 60 employers met in groups of 6 for roundtables
  - Employers expressed their needs for training
  - Employers gave a gradecard to NSCC
- The college had to make some changes





# HOME4TECHS

## Hands On Maintenance Education 4 TECHnicians



### Problem:

- Curriculum needed realignment to employer needs
- Traditional college schedules no longer works for employers
- Inconsistent skill levels of graduates
- Completion of traditional college certificate/degrees take too long

### Solution:

- Redesign the curriculum to meet employers needs
- Build a **competency-based, hybrid instructional model**
- Require individual skill assessments
- Move the courses' **lecture portion to an online format**
- Utilize technology tools to accelerate learning
- Offer the students a **flexible open-lab schedule**

### Project consists of 3 distinct areas:

#### Curriculum

- Realignment of curriculum
- Competency-based learning
- Hybrid course model
- Modular online eLearning
- Hands-on assessments
- Open lab learning model

#### Technology to accelerate learning

- Virtual machines for each student
- Hands-on hardware simulations
- Student access to software 24/7
- Virtual interactive simulations
- MOOCs

#### Faculty professional development

- Quality matters
- Instructional systems design
- Online course development
- Instructing online courses
- Technical content cross-training
- Learning object development



northweststate.edu/HOME4TECHS



- Curriculum needed realignment to employer needs
- Traditional college schedules no longer works for employers
- Inconsistent skill levels of graduates
- Completion of traditional college certificate/degrees take too long







# HOME4TECHS

Hands On Maintenance Education 4 TECHnicians



## Problem:

- Curriculum needed realignment to employer needs
- Traditional college schedules no longer works for employers
- Inconsistent skill levels of graduates
- Completion of traditional college certificate/degrees take too long

## Solution:

- Redesign the curriculum to meet employers needs
- Build a **competency-based, hybrid instructional model**
- Require individual skill assessments
- Move the courses' **lecture portion to an online format**
- Utilize technology tools to accelerate learning
- Offer the students a **flexible open-lab schedule**

## Project consists of 3 distinct areas:

### Curriculum

- Realignment of curriculum
- Competency-based learning
- Hybrid course model
- Modular online eLearning
- Hands-on assessments
- Open lab learning model

### Technology to accelerate learning

- Virtual machines for each student
- Hands-on hardware simulations
- Student access to software 24/7
- Virtual interactive simulations
- MOOCs

### Faculty professional development

- Quality matters
- Instructional systems design
- Online course development
- Instructing online courses
- Technical content cross-training
- Learning object development

- Redesign the curriculum to meet employers needs
- Build a **competency-based, hybrid instructional model**
- Require individual skill assessments
- Move the courses' **lecture portion to an online format**
- Utilize technology tools to accelerate learning
- Offer the students a **flexible open-lab schedule**



northweststate.edu/HOME4TECHS







# HOME4TECHS

Hands On Maintenance Education 4 TECHnicians



## Problem:

- Curriculum needed realignment to employer needs
- Traditional college schedules no longer works for employers
- Inconsistent skill levels of graduates
- Completion of traditional college certificate/degrees take too long

## Solution:

- Redesign the curriculum to meet employers needs
- Build a **competency-based, hybrid instructional model**
- Require individual skill assessments
- Move the courses' **lecture portion to an online format**
- Utilize technology tools to accelerate learning
- Offer the students a **flexible open-lab schedule**

## Project consists of 3 distinct areas:

### Curriculum

- Realignment of curriculum
- Competency-based learning
- Hybrid course model
- Modular online eLearning
- Hands-on assessments
- Open lab learning model

### Technology to accelerate learning

- Virtual machines for each student
- Hands-on hardware simulations
- Student access to software 24/7
- Virtual interactive simulations
- MOOCs

### Faculty professional development

- Quality matters
- Instructional systems design
- Online course development
- Instructing online courses
- Technical content cross-training
- Learning object development



**Programmable Controller Course**  
Allen Bradley MicroLogix and CompactLogix

**Motors & Controls**  
Allen Bradley PowerFlex 70s and 525s

**Servo & Robotics**  
Fanuc LR Mate 200iD

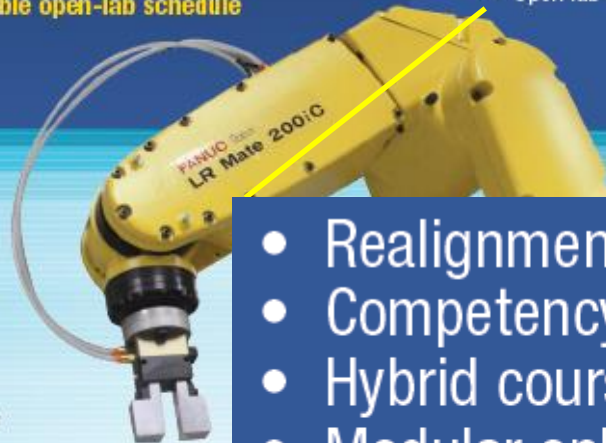

- Realignment of curriculum
- Competency-based learning
- Hybrid course model
- Modular online eLearning
- Hands-on assessments
- Open lab learning model







# HOME4TECHS

Hands On Maintenance Education 4 TECHnicians



## Problem:

- Curriculum needed realignment to employer needs
- Traditional college schedules no longer works for employers
- Inconsistent skill levels of graduates
- Completion of traditional college certificate/degrees take too long

## Solution:

- Redesign the curriculum to meet employers needs
- Build a **competency-based, hybrid instructional model**
- Require individual skill assessments
- Move the courses' **lecture portion to an online format**
- Utilize technology tools to accelerate learning
- Offer the students a **flexible open-lab schedule**

## Project consists of 3 distinct areas:

### Curriculum

- Realignment of curriculum
- Competency-based learning
- Hybrid course model
- Modular online eLearning
- Hands-on assessments
- Open lab learning model

### Technology to accelerate learning

- Virtual machines for each student
- Hands-on hardware simulations
- Student access to software 24/7
- Virtual interactive simulations
- MOOCs

### Faculty professional development

- Quality matters
- Instructional systems design
- Online course development
- Instructing online courses
- Technical content cross-training
- Learning object development

- Virtual machines for each student
- Hands-on hardware simulations
- Student access to software 24/7
- Virtual interactive simulations
- MOOCs



**Programmable Controller Course**  
Allen Bradley MicroLogix and CompactLogix

**Motors & Controls**  
Allen Bradley PowerFlex 70s and 525s

**Servo & Robotics**  
Fanuc LR Mate 200iD







# HOME4TECHS

Hands On Maintenance Education 4 TECHnicians



## Problem:

- Curriculum needed realignment to employer needs
- Traditional college schedules no longer works for employers
- Inconsistent skill levels of graduates
- Completion of traditional college certificate/degrees take too long

## Solution:

- Redesign the curriculum to meet employers needs
- Build a **competency-based, hybrid instructional model**
- Require individual skill assessments
- Move the courses' **lecture portion to an online format**
- Utilize technology tools to accelerate learning
- Offer the students a **flexible open-lab schedule**

## Project consists of 3 distinct areas:

### Curriculum

- Realignment of curriculum
- Competency-based learning
- Hybrid course model
- Modular online eLearning
- Hands-on assessments
- Open lab learning model

### Technology to accelerate learning

- Virtual machines for each student
- Hands-on hardware simulations
- Student access to software 24/7
- Virtual interactive simulations
- MOOCs

### Faculty professional development

- Quality matters
- Instructional systems design
- Online course development
- Instructing online courses
- Technical content cross-training
- Learning object development



**Programmable Controller Course**  
Allen Bradley MicroLogix and CompactLogix

**Motors & Controls**  
Allen Bradley PowerFlex 70s and 525s

**Servo & Robotics**  
Fanuc LR Mate 200iD



- Quality matters
- Instructional systems design
- Online course development
- Instructing online courses
- Technical content cross-training
- Learning object development







## Original Technical Course Model at NSCC

Course Outcomes	Student Materials	Delivery Method	Student Pacing	Hands-on Experience	Assessment	Delivery Timeframe
Based on Textbook	Based on Textbook	F to F Lecture Instructor	Based on Instructor	Lab Exercises to support lecture	Grade based on 3 tests	16 week semester

A traditional technical course offered at many 2-year colleges

## Competency-Based, Hybrid, Flexible-Lab Course Model (NSCC)

Course Outcomes	Student Materials	Delivery Method	Student Pacing	Hands-on Experience	Assessment	Delivery Timeframe
Aligned with Industry Skills Requirements	Active Learning: Videos, Voice over PPT, Simulations. PDF, OER, Textbooks	Hybrid, Lecture Online Labs on Campus	Flexible: Student masters module then moves to next module	Labs used to develop skills and prepare for HOA	Hands-on Assessment (HOA) 100% skills mastery (8 HOAs & 8 LMS Assessments/course)	8 week mini-semester (Part of Term)

## Traditional Course Model, scaled to include Outcomes & Assessment

Course Outcomes	Student Materials	Delivery Method	Student Pacing	Hands-on Experience	Assessment	Delivery Timeframe
Aligned with Industry Skills Requirements	Based on Textbook	F to F Lecture Instructor	Based on Instructor	Lab Exercises to support lecture	Hands-on Assessment (HOA) 100% skills mastery	16 week semester

A traditional technical course scaled to include the Course Outcomes & Assessment from the Competency-based Model



## Student Grades in the NSCC model:

- The grades the students are awarded in the NSCC Ind. Tech hybrid courses are: A, B or F.
- The hands-on assessment (HOA) must have 100% mastery, so students have to get 100. This is not averaged into the grade. It is required.
- The knowledge & application assessment (KAA for short) is the cognitive, online assessment. Student have to get at least an 80% on this assessment to pass the module. They have two tries at taking KAA in each module.
- 16 assessments in each course (8 online, 8 hands-on)

## A Few Lessons Learned cont.:

- This model has moved the student learning off the shoulders of the faculty, to the student. Students are responsible for their learning, and when they take their assessments.
- Employers really like this model since all of the curriculum is developed. A positive thing for the companies was if they sponsored students into a course that had two sections with two different instructors, the students get the same learning experience. Reducing the variance.



## Traditional Education vs. Competency-Based

- Traditional education has a set time (16 weeks), and variable education (5 possible grades, and how much was actually learned).
- Competency-based education has set level of education/learning (mastery), and variable time (students progress based on their learning), where some students can finish early, but some may take a little longer.

## Traditional Education vs. Competency-Based

- In a traditional model, the faculty does primarily teaching, and some assessment
- In a competency-based model, the faculty does primarily assessment, and less teaching than in the traditional model

## What is Competency-based Education (CBE)?

- Competency-based Education consists of two important element:
  - **Mastery of Skills** - The CBE course is typically parsed into modules, with assessments in each module that must be passed at the mastery level.
  - **Flexible Pacing** - Student will progress through a course at their pace of learning (and of course mastery). Some students will finish early, and some will take a little longer.



## External Data

### Topic Resources

Advisory Board  
Job Descriptions  
DACUM Comp.  
WFD Demand  
Employer RT  
Corp. Faculty

### Job Classifications

Maintenance Mechanic  
  
Electrician  
  
Machine Setup

## Delivery of Product

### Credit Cert/Degrees

2 Yr. AAS, ATS, AIS  
One-year Cert.  
Gainful Empl. Cert.  
Apprenticeships

Ind. Automation Maint. Cert.  
Industrial Elect. Cert.  
Industrial Maintenance Degree  
Automation Cert.

### Short Term Public Classes

Students come to the college  
4 hr. to 24 hr. courses  
Credit or N/C

AB PowerFlex 525 VFDs

### Contract Training

Students come to the college  
College delivers at company  
4 hr. to 24 hr. courses  
Credit or N/C

AB PowerFlex 525 VFDs  
Intro to AB ControlLogix

## Internal Product

### Technical Topics

Basic Electrical  
Handtools  
Powertools  
Ind. Safety  
Pneumatics  
Hydraulics  
Mech Print Read  
Motor Control Cir  
Motors & VFDs  
PLC Basics  
AB CompactLogix  
AB ControlLogix  
Ethernet basics  
Rigging  
Pumps  
Pipefitting basics  
Machine Repair

### Technical Courses

IND120 IE1  
IND121 IEII  
IND223 M&C  
PLC200 PLCI  
IND134 IFPI

### Types of Students

Incumbent

Emerging

Displaced

Underemployed

Technical Courses

# Engaging Employers

- How does the Tech division at RCC engage employers?
- Accrediting bodies like a comprehensive employer engagement strategy.
- Purpose of an Advisory Board
- Purpose of an Industry Roundtable
- Purpose of a Focused Industry Visit

## Employer Roundtables:

- Ask employers to send 1-2 SMEs to a meeting on a technology. Try to get at least 6-8 participants.
- Focus on a technology cluster
- My best results is 3pm on a weekday (not Fridays), for no more than 1 hour
- Do not give them a book, or a blank sheet of paper. Give them no more than 2 pages of topic outline to review.
- Send these 2 pages to them by email, 2-4 days prior to the roundtable



## Competencies versus Learning Objective (Outcome)

- A **Competency** is often tied to a job description or role. A capacity that exists in a person that leads to behavior that meets the job demand.
- A **Learning Objective** describes the specific knowledge, ability or behavior expected from the student after completing the learning cycle.

## What is an Assessment Model?

- Traditional technical courses typically uses a written/online assessment for the course.
- In a Competency-based course, the faculty must verify the student learning (both knowledge & skills) through a demonstration (HOA).
- The assessment model verifies that a student get credit for a course, either by taking the course, or by a PLA. The assessment should be the same.

## Competency-Based Assessment

- The term CBA stands for Competency-Based Assessments. This assessment must be in place to assess mastery in a CBE model.
- Since the course content is parsed into multiple modules (8 modules for the NSCC model), there will need to be an assessment for each module, to prove mastery, so the student can move to the next module.
- There will be more assessments for students to take (and for faculty to create) in a CBE model



## Assessment by Faculty

- Assessment is the responsibility of the faculty.
- Student skills and knowledge are both assessed by the faculty in the HOA process.
- Knowledge is also assessed through an online assessment for each module that faculty developed, which consists of M.C. and T.F. questions
- LMS efficiency saves faculty valuable time
- The assigned instructor objectively determines if a student passes a module, and the course.

## Purpose of the Hands-On Assessment

- The purpose of the HOA is so a student can demonstrate mastery of a learning module to the faculty.
- An HOA is much more than just putting something together, or adjusting a machine. The faculty will ask the student questions on the topic, similar to what a student will experience in an interview.

## Elements of a Hands-On Assessment

- The student does a task specified by the HOA for the faculty. This task must be related to the tasks performed in the workplace.
- Interpret workplace documentation (P&ID diagrams)
- Faculty asks student questions from the lab exercises and the KAA
- Many times the student must also troubleshoot a circuit, or a machine



## The purpose of Lab Exercises:

- The purpose of a lab exercise is to guide the student through a learning process that will develop their knowledge & skills for the workplace.
- Lab exercises are performed in teams of 2-3 students (though they are assessed individually), for the purpose of developing small group communication skills, and teamwork. Students have to solve problems together, and practice the HOA on each other, thus developing actual skills they need in the workplace.

## Creating Hands-on Assessments & Lab Exercises

- The student must earn 100% for each HOA, before moving to the next module. This is mastery of skills.
- The HOA grade is not averaged, it is required to be 100%
- The faculty decides if the student advances to the next module, and if the student passes the course.

### Lab Procedure 4.1: A.S. Automatic Return Circuit and Flow Control

A student lab exercise, or lab procedure (same thing) is a directed/guided learning experience for the student.

Questions about the learning within the lab exercise, should be asked in the Hands-On Assessment (HOA)

Upon completion of this lab procedure, the student should be able to:

1. Download the simulation file from the Message Center in Sakai, in the Virtual Machine.
2. Open the simulation file in Automation Studio, and start the simulation
3. Identify and explain the purpose of each component on the pneumatic print
4. Explain the basic operation of the pneumatic circuit
5. Explain the purpose of using flow control valves in an automatic circuit
6. Determine which flow valve affects the extension and retraction of the cylinder
7. Predict the pressure that would be measured at any port in the circuit

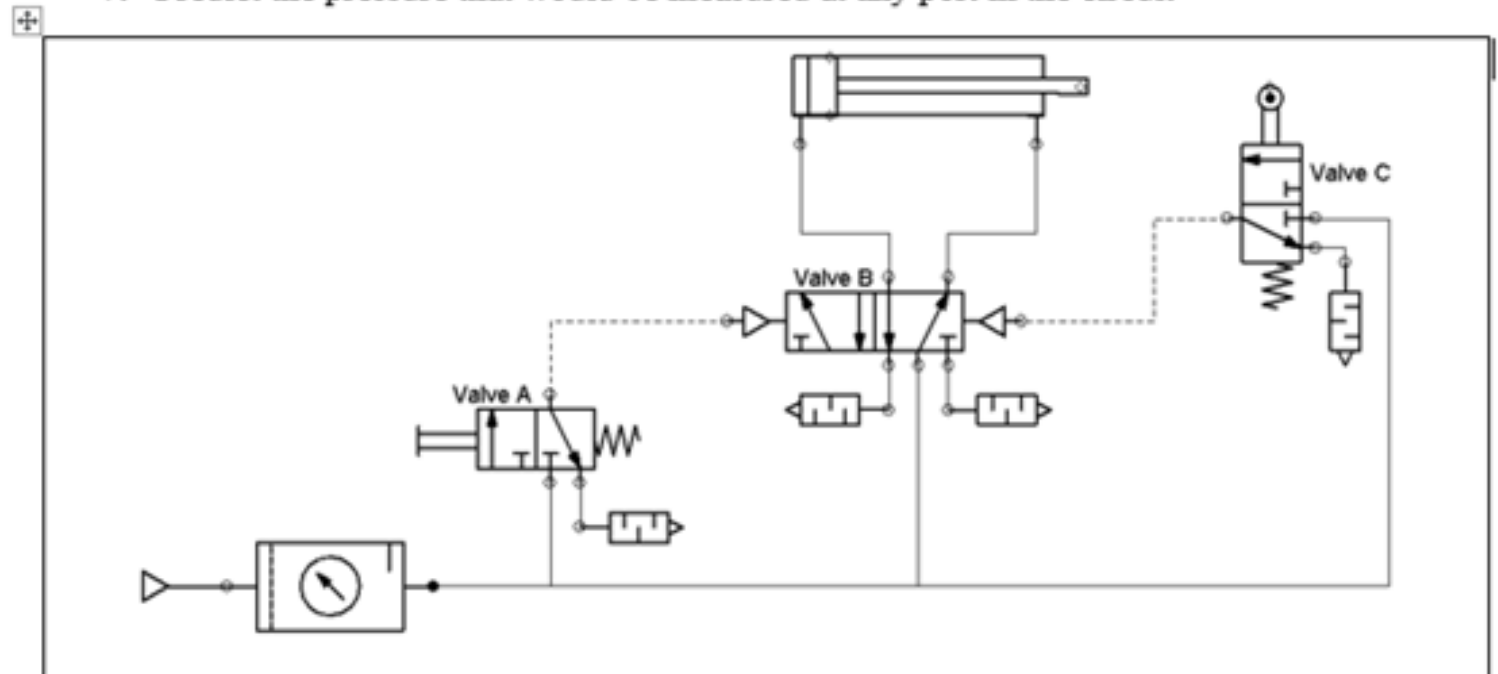

Figure 1. An Auto Return circuit, Lab 4.1 Circuit 1.



A student lab exercise, or lab procedure (same thing) is a directed/guided learning experience for the student.

Questions about the learning within the lab exercise, should be asked in the Hands-On Assessment (HOA)

Upon completion of this lab the student should be able to:

1. Wire the power and control circuit of a GS2 VFD
2. Configure the parameters on the GS2 to meet drive operational specifications
3. Interpret the display information on a GS2 drive
4. Load the motor of a GS2 to see the operation of the drive under load
5. Recover the GS2 from a fault condition
6. Wire in pilot lights to the relay outputs of the GS2 and define their operation

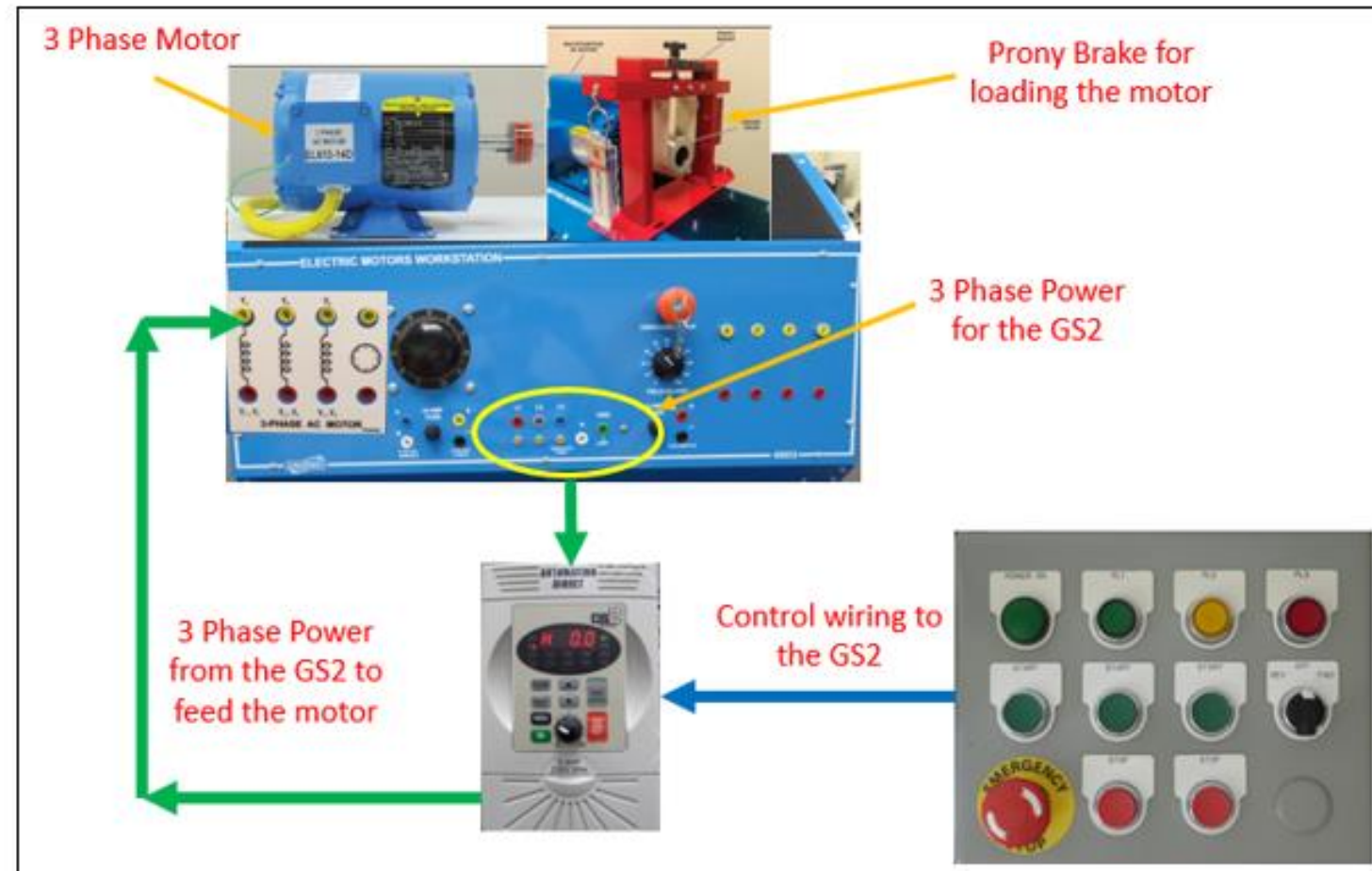

## The purpose of Lab Exercises:

- The purpose of a lab exercise is to guide the student through a learning process that will develop their knowledge & skills for the workplace.
- Lab exercises are performed in teams of 2-3 students (though they are assessed individually), for the purpose of developing small group communication skills, and teamwork. Students have to solve problems together, and practice the HOA on each other, thus developing actual skills they need in the workplace.

# Hands-On Assessments (HOA)

## Example of an HOA

- Build an operational circuit from an electrical print
- Explain the operation of the circuit to the instructor
- Demonstrate the knowledge on an electrical print
- Predict the operation of a circuit based on certain criteria
- Troubleshoot a faulty circuit

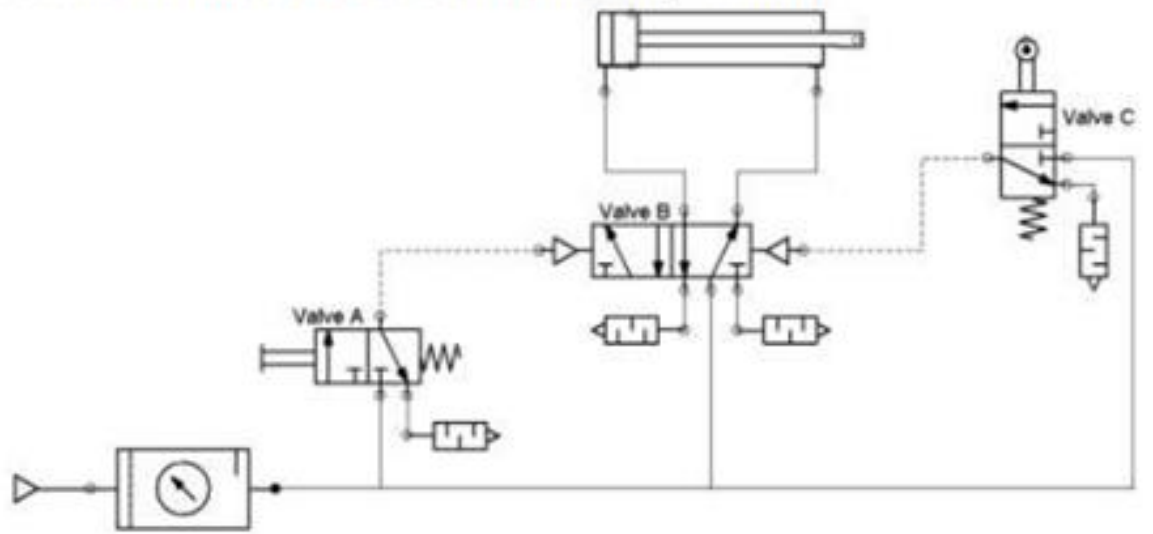

## A Hands-On Assessment in a Fluid Power course

_____	7.	<p>Assemble this circuit in the lab, and make it operational.</p> 
_____	8.	Demonstrate the operation of the circuit to the instructor.
_____	9.	Explain the operation of the circuit to the instructor.
_____	10.	Explain to the instructor what the pressure reading should be on the blind side port, when Valve A is actuated.
_____	11.	Explain to the instructor what the pressure reading should be on the rod side port of the cylinder, when Valve C is actuated.
_____	12.	Troubleshoot a fault the instructor will put into the circuit, after a brief absence of the student.

# A Hands-On Assessment from Industrial Electrical II

Student Name: \_\_\_\_\_ N# \_\_\_\_\_ Date: \_\_\_\_\_

This hands-on assessment requires that each student successfully demonstrates each of these tasks to the instructor's satisfaction. There is no grade for this assessment.

Prior to taking this assessment, the student must pass (minimum of 80%) the Knowledge and Application Assessment.

The student cannot proceed to the HOA for the next module without completing this HOA.

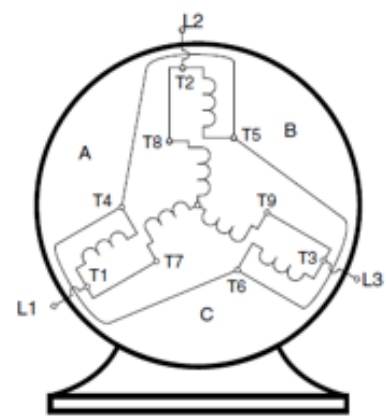

Check	#	Skills Task
_____	1.	Wire a 9 lead dual voltage three phase motor 
_____	2.	Interpret the nameplate data on an AC three phase motor
_____	3.	Reverse the rotation of a three phase motor
_____	4.	Troubleshoot the power circuit of an industrial motor branch circuit

# A Hands-On Assessment from Industrial Electrical II

5. Interpret electrical prints with motor branch circuits (print below)

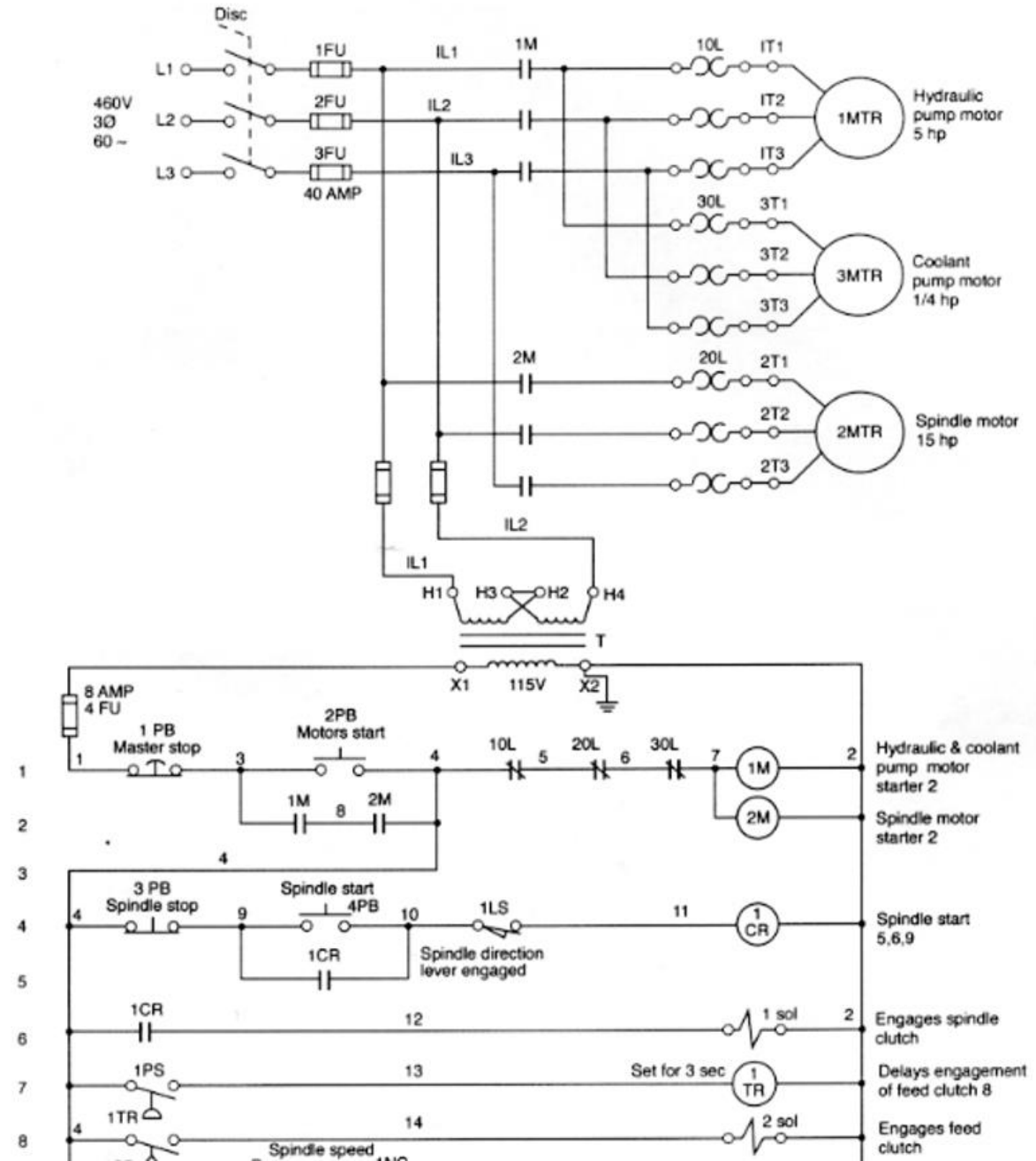

Which one of the following answers would explain what could be wrong, if in this 90 PSI circuit, the user measured 90 PSI at the port designated as #1, and 0 PSI at the port designated as #4?

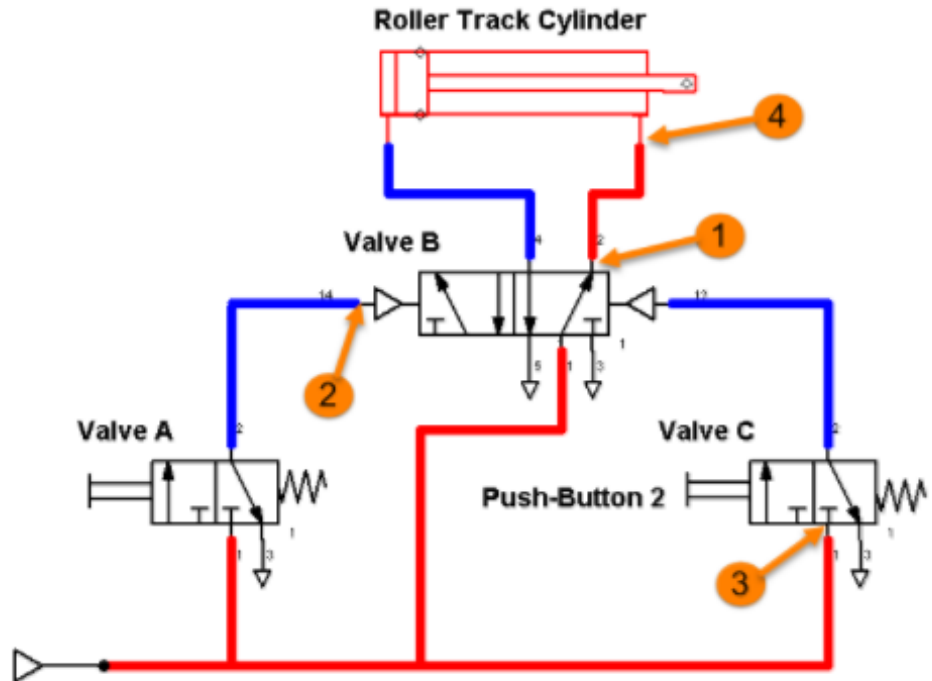

## A sample question in a KAA for Fluid Power

- A. The directional control valve is stuck in the default position
- B. The spring return is broken on Valve C
- C. The exhaust port #3 is not porting to atmosphere
- D. The air hose between #1 and #4 is plugged

Answer Key:D



Based on the pneumatic print on the left side, the object with the number "3", would correlate to which device on the training board (right side of graphic)?

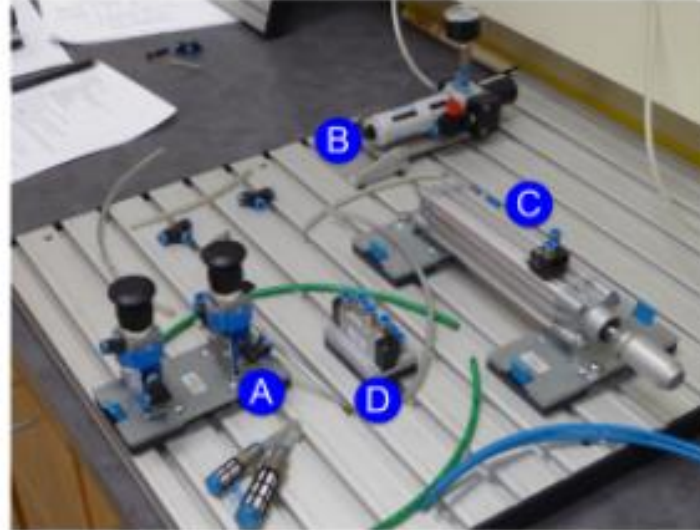
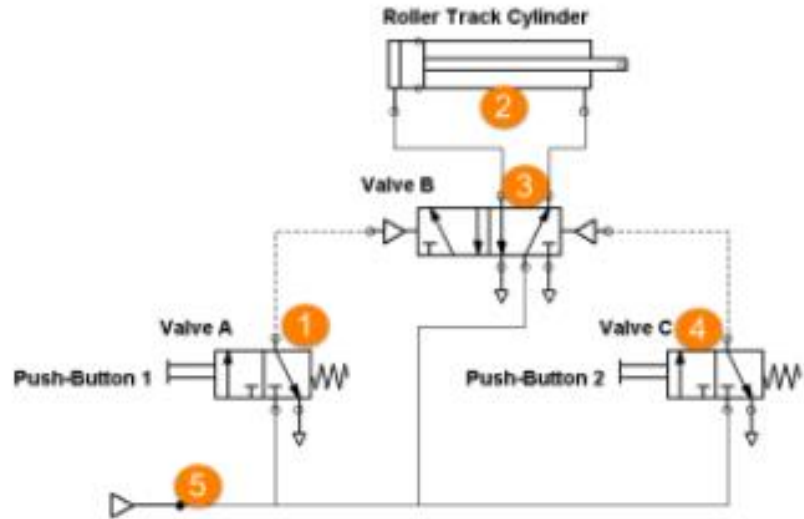

- A. A
- B. B
- C. C
- D. D

Answer Key:D

**A sample question in  
a KAA for Fluid Power**

Which components in Figure 2, would be inclusive of the conditioning unit in Figure 1?

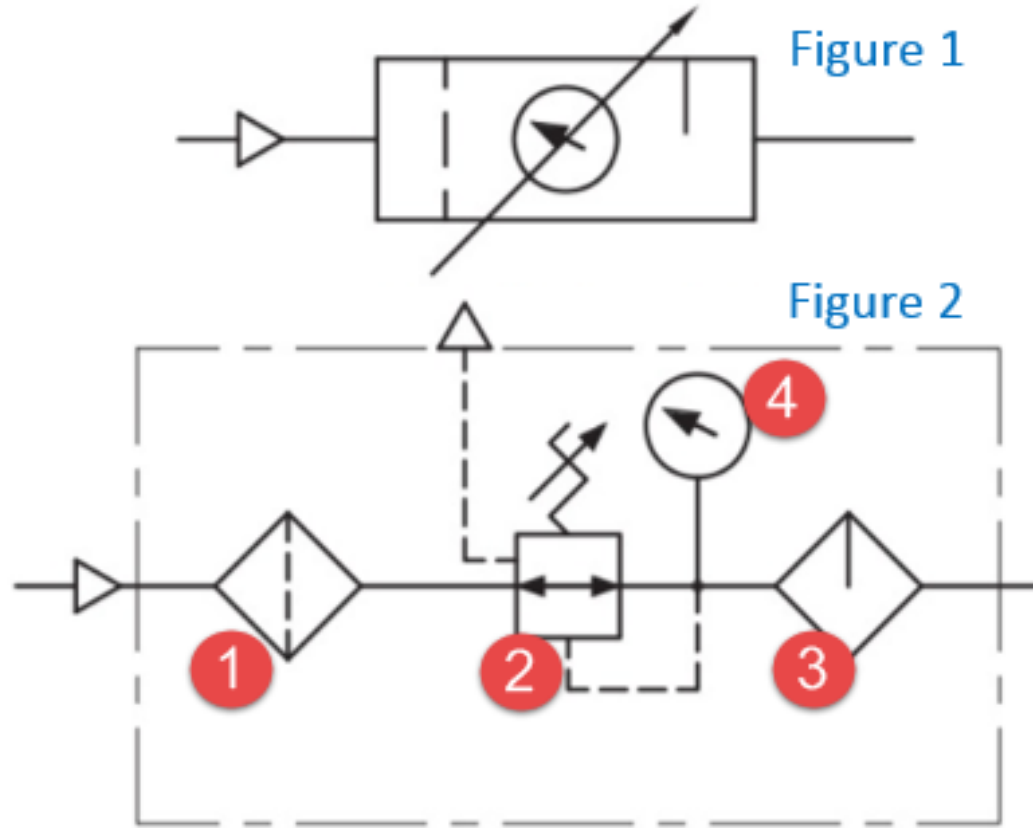

**A sample question in a KAA for Fluid Power**

- A. 2
- B. 2 & 4
- C. 2, 3 & 4
- D. 1, 2, 3 & 4

**Answer Key:D**

## Practice Quizzes are a Formative Assessment & Learning Tool

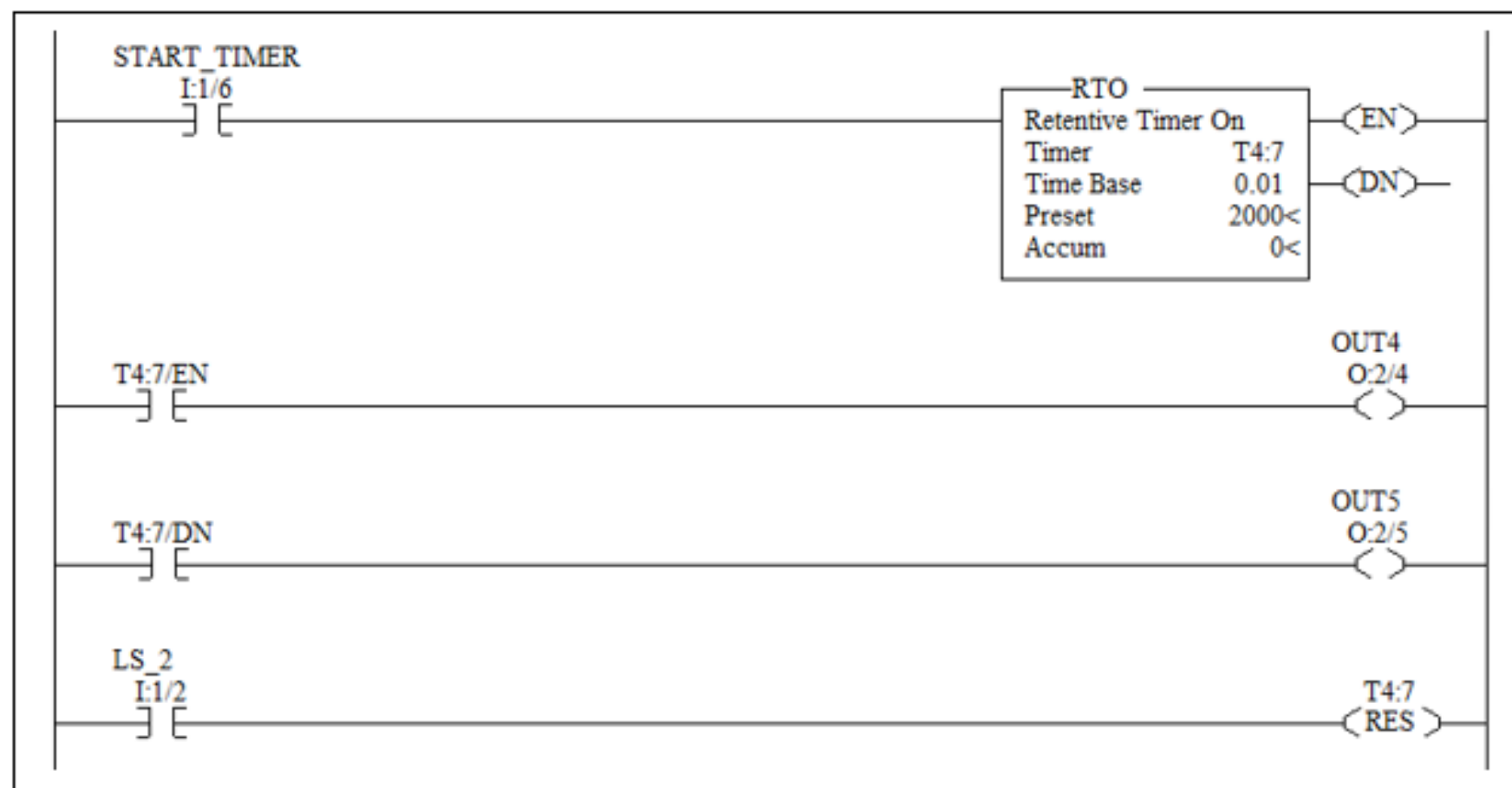

11. In this program, if the START\_TIMER input is turned on for 7 seconds, then the input is shut off, what will be the accumulated value?
- 70
  - 700**
  - 7000
  - 0

Explanation: If the timer times for 7 seconds, the accumulated value will be 700. When the input (START\_TIMER) is shut off, the accumulated value remains at 700. When LS\_2 is actuated, the RES instruction is energized, then the accumulated value will reset to 0.

## Practice Quizzes are a Formative Assessment & Learning Tool

1. T F The GS2 has 3 analog inputs to control the speed of the VFD: 0-10Vdc, 0-20mA and 4-20mA.

Explanation: The GS2 has only one analog input. Terminal AI (analog input) is the terminal number, and the ACM terminal is the analog common. If the user wants to use an external potentiometer to control the speed, the potentiometer is wired as shown on the diagram. The signal coming into the AI terminal will be 0-10V. Realize that the user can also control the drive with an external signal that would come from an analog output module from a PLC system. These analog output modules can usually be setup for voltage or current. In this case, the drive could be controlled by 0-10Vdc, 0-20mA or 4-20mA analog signal to control the speed.

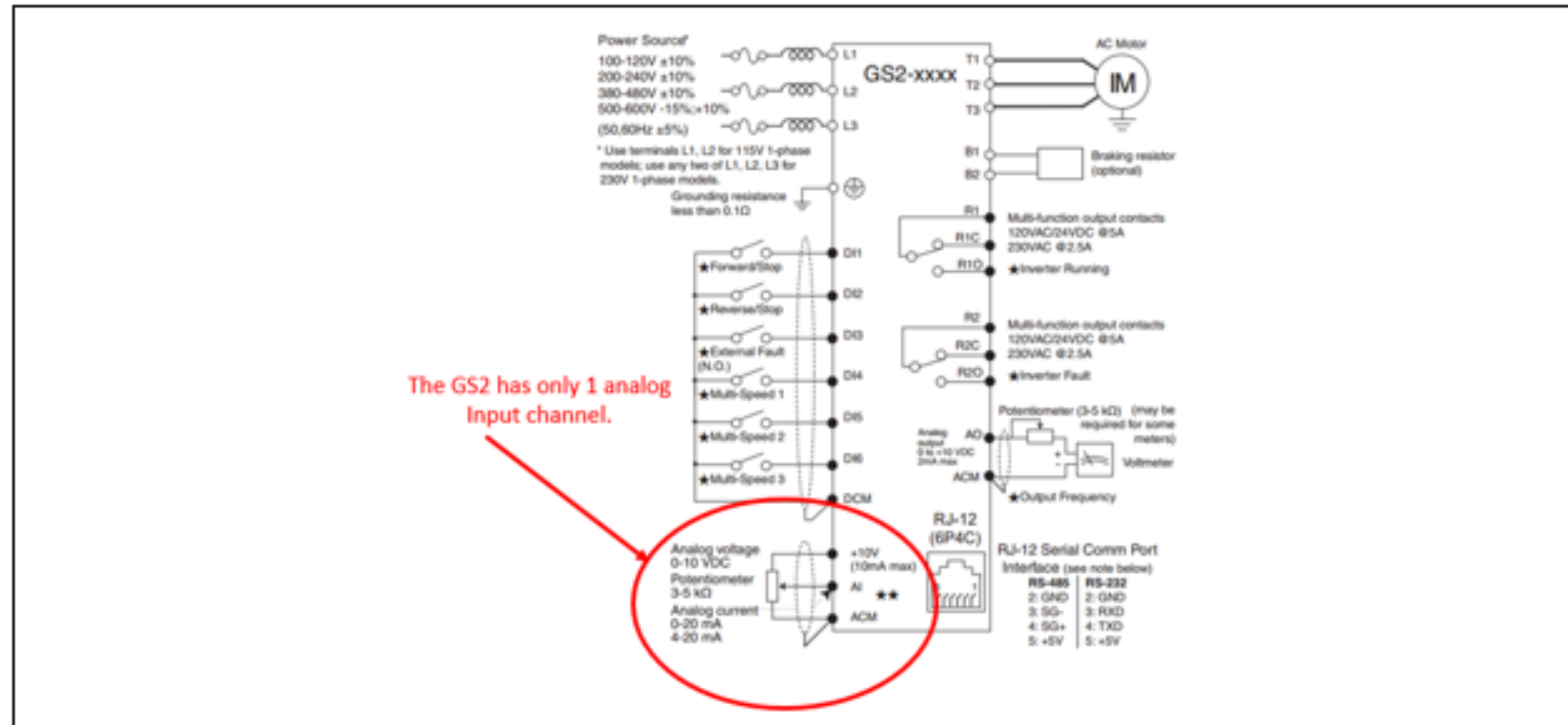



# Learning Objects in a Technical Course

## Topic Outcomes:

- List the different digital learning objects that can be used in the online portion of a technical course
- Determine where to find OER material that can be reused in a course
- Determine the software tools and hardware needed to create online learning objects
- Identify learning objects that will be used in a specific module for a technical course
- Discuss copyright issues and how to reuse content from an equipment vendor

## Learning Objects in an Online Module

- Learning objects are elements used in an online learning module that will present instructional content to students in different ways.
- Different types of learning objects:
  - Contained: Adobe Captivate, Articulate Storyline
  - Videos
  - PDF/mini eBooks
  - Voice over PPT
  - Podcasts
  - Simulations

## What is needed to Develop the Objects

- Videos: Camera (point & shoot) is fine. Camtasia will be needed to compress it for upload to YouTube.
- PDF Files: Camera to take photos, and PowerPoint to use as a graphic container. Text can be added. Export as a PDF. Word can also be used as a container.
- Voice over PPT: Camera, PowerPoint, Wacom tablet to annotate on the graphics, headset, and Camtasia Recorder. Camtasia Studio is used to produce, then load to YouTube.
- Podcast: Microphone and Audacity (open source)
- Simulation: More explanation coming

- In Module 5 of the Sakai LMS, open a graphic file (there are 6-7 of them listed).
- Use Snagit to capture a portion of the picture, and copy it to the clipboard
- Open the PowerPoint file used for scratch graphics. Paste the clipped graphic into the PPT.
- Use arrows and text boxes to illustrate the graphic



## Learning Objects in an Online Module, cont.

- Learning objects can also be information from a vendor site, such as an informational PDF document on how their project works, or a specification sheet on their produce. It is important to have some of this in the curriculum, since this is what students will be using on the job.
- If you use information from a vendor site, put the link to the document in the LMS.

## Learning Objects in an Online Module, cont.

- OER - Open Educational Resource material. This is free material that can be used by any public or private sector person.
- CCby is the logo at the bottom of most documents that will allow the user to edit and modify a document to be customized to a specific purpose.
- Skillscommons is the DOL repository
- ATE Central is the NSF repository
- Any object created with federal dollars through a grant, should be loaded onto one of these two websites

### DOL DISCLAIMER:

This product was funded by a grant awarded by the U.S. Department of Labor's Employment and Training Administration. The product was created by the grantee and does not necessarily reflect the official position of the U.S. Department of Labor. The Department of Labor makes no guarantees, warranties, or assurances of any kind, express or implied, with respect to such information, including any information on linked sites and including, but not limited to, accuracy of the information or its completeness, timeliness, usefulness, adequacy, continued availability, or ownership.



This work is licensed under a [Creative Commons Attribution 4.0 International License](https://creativecommons.org/licenses/by/4.0/).

## Learning Objects in an Online Module, cont.

- Some common digital learning object that work well in HOME4TECHS:
  - Powerpoint with graphics and text that explain a subject, or concept. These files are converted to PDF, so any device or computer can view it.
  - Video created of an instructor showing how something works, or how to do something. A point and shoot or higher end camera is used for this, then compressed using Camtasia. This is then loaded to YouTube on an unlisted channel.

## Learning Objects in an Online Module, cont.

- Some common digital learning object that work well in HOME4TECHS:
  - Voice over PPT, which is then converted to a video with Camtasia. This is the most popular with students. It is like the instructor is drawing on a graphic, on a whiteboard.
  - Simulations created with proprietary software such as Automation Studio, which will do simulations in fluid power and electrical systems. Students actually interact with the simulation. These are run inside a student Virtual Machine



# Example of an interactive Simulation in Fluid Power I

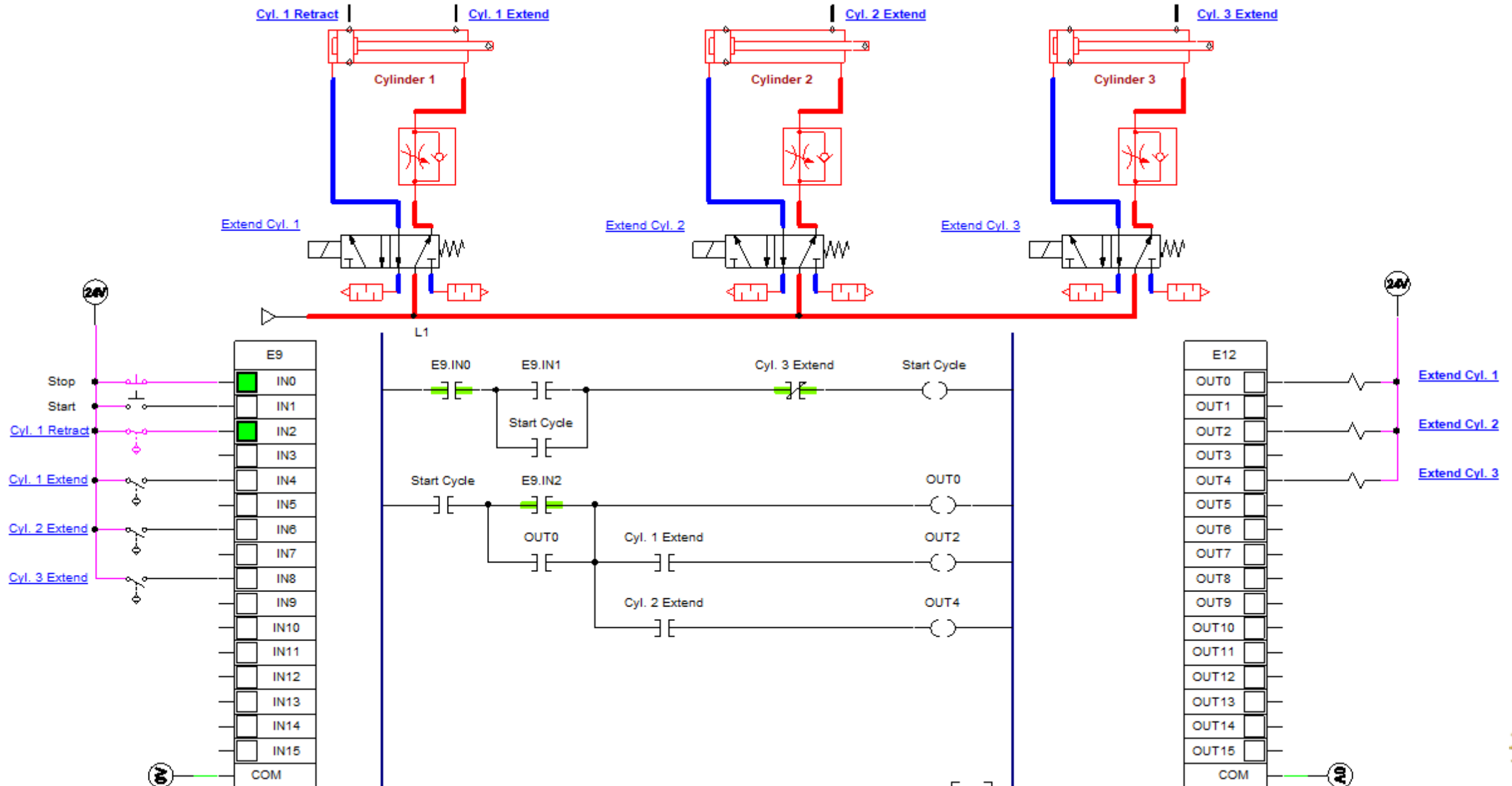

## Example of an interactive Simulation in PLC I

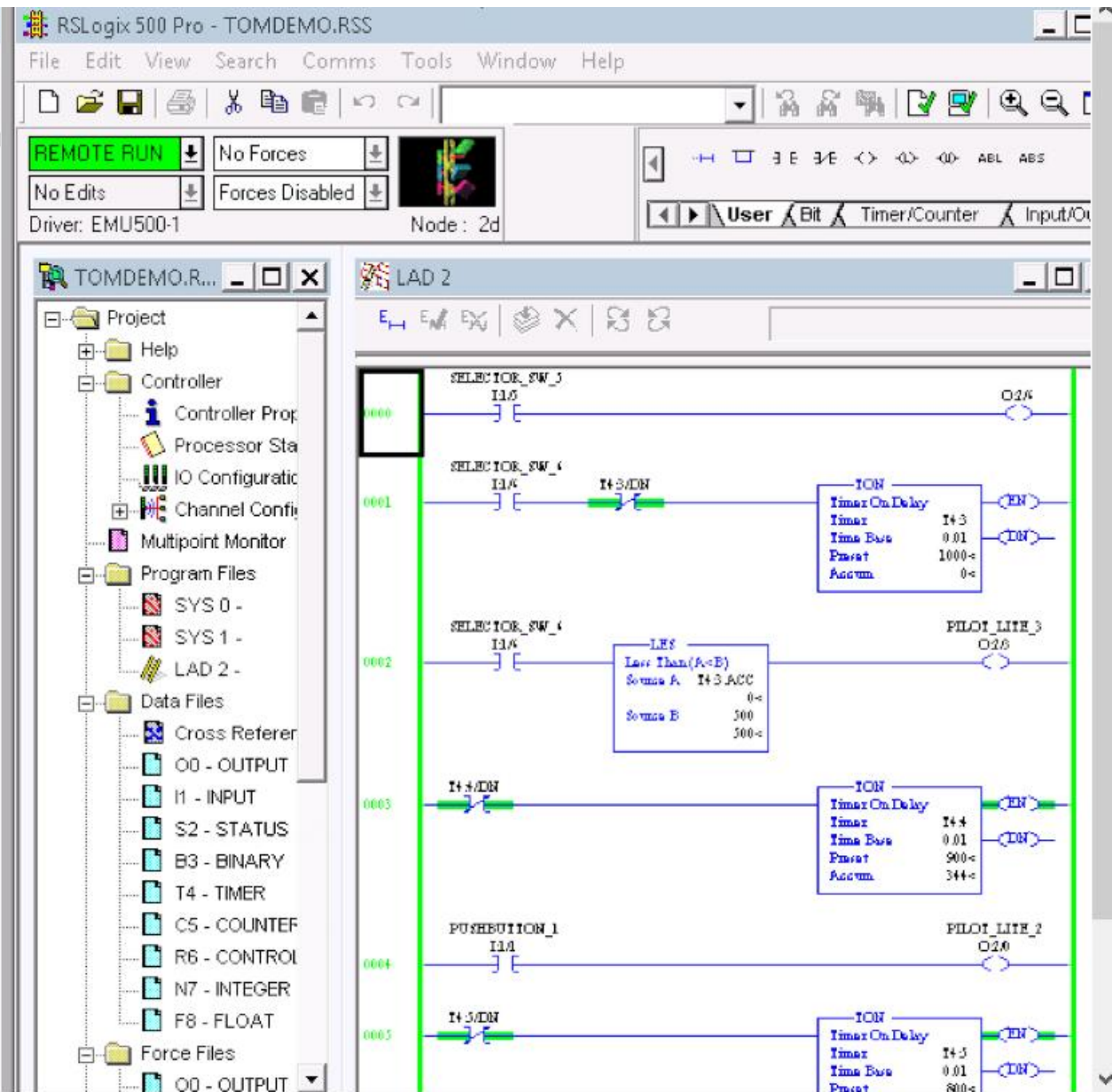
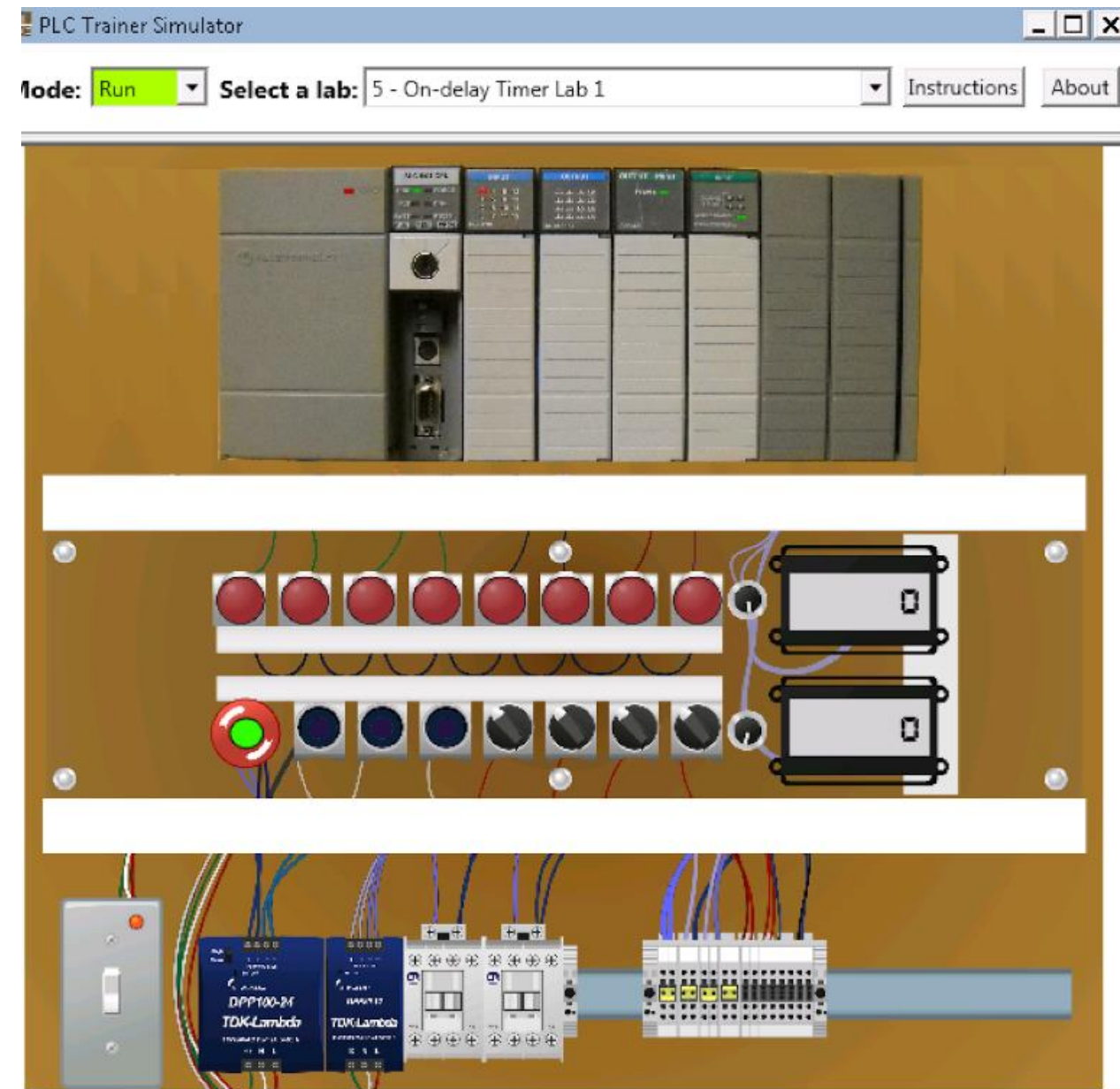

## Using Reverse Design to Convert/Create a Course

- The SCALE\_UP project will also walk the faculty from the partner colleges through the conversion of 2 technical courses to a modular CB/H model.
- One course to be converted and updated is the Instrumentation & Controls course at NSCC
- Another proposed course is the Electrical Systems Troubleshooting course
- Faculty will learn Instructional Systems Design

# Reverse Design

It is best to initially run the course in a standard format, to establish the correlation between content and credit/contact hours. This establishes baseline data for the cross walk between competencies and credit/contact hours.

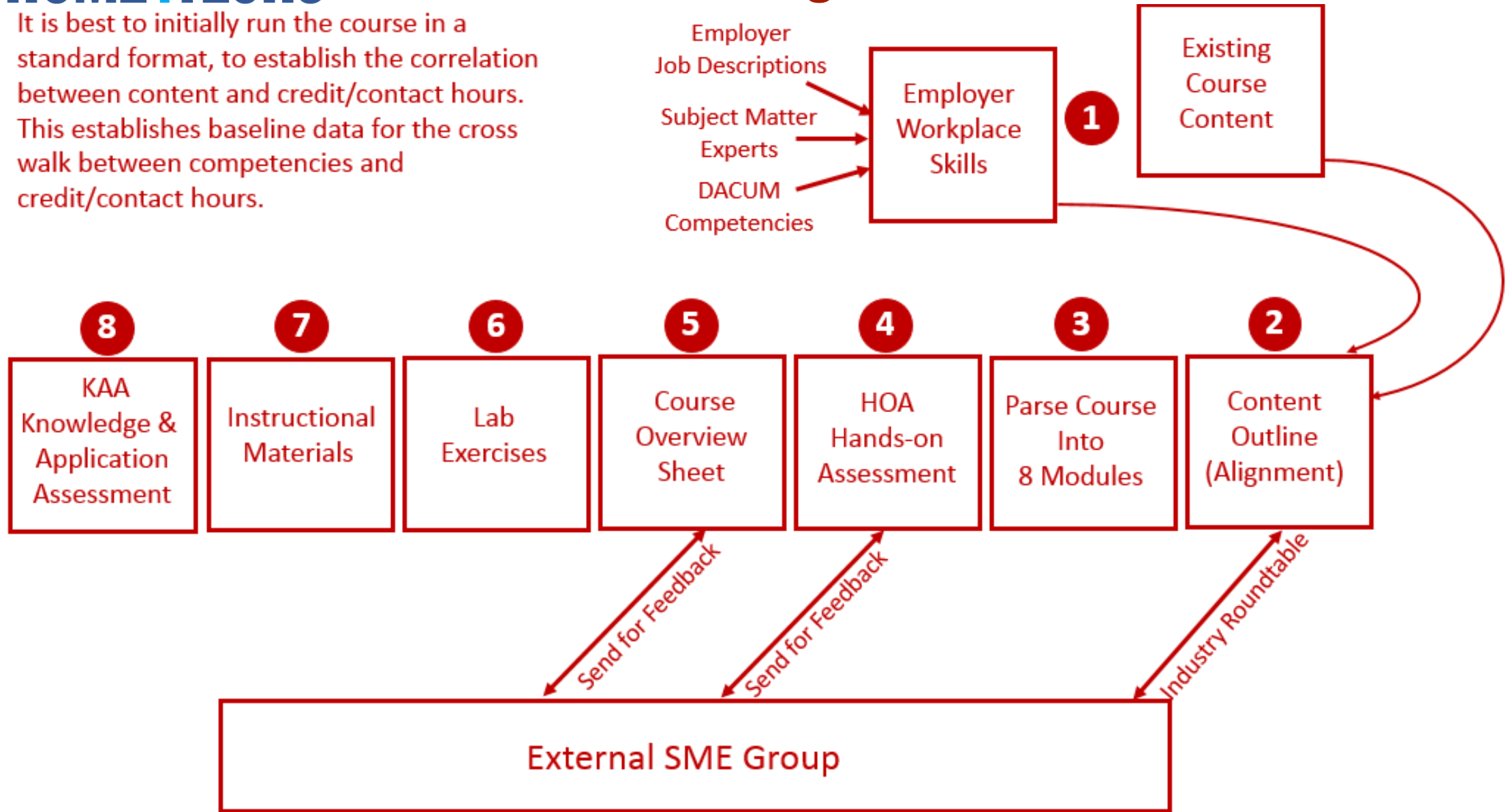

# The End of the Presentation