

# Single and Three Phase Power

Developed by Tom Wylie, 2/9/17

# Single and Three Phase Power

After viewing this document, the student should be able to:

1. Explain the basic single and three phase power systems used in an industrial environment
2. Determine what voltage the user would measure on a three phase power system
3. Determine what voltage the user would measure on a single phase, Edison system
4. Identify the power connections in a single phase residential panel
5. Calculate  $V_{peak}$  from  $V_{rms}$ , and  $V_{rms}$  from  $V_{peak}$
6. Identify a Wye and Delta three phase configuration
7. List the most common single phase voltages used in an industrial environment
8. List the most common three phase voltages used in an industrial environment
9. Determine the voltage measured phase to phase on a 3-phase delta system
10. Determine the voltage measured phase to phase on a 3-phase wye system
11. Determine the voltage measured from phase to neutral on a 3-phase wye system
12. Determine the voltage ratings on an electrical disconnect

# AC Sine Wave

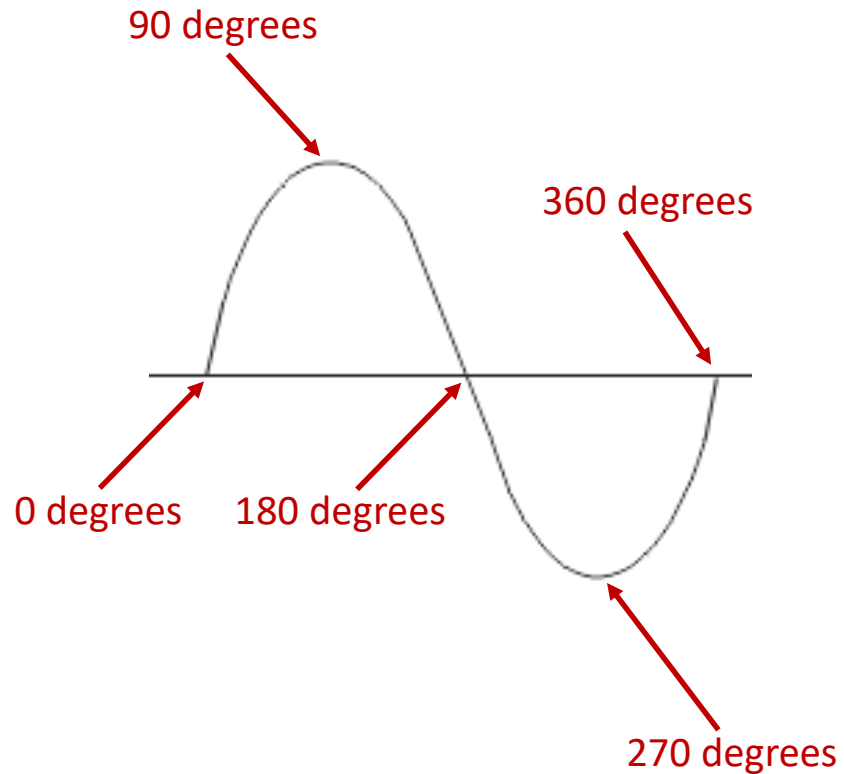

The AC sine wave is the waveform a student would see if an oscilloscope was connected to AC power. This waveform is created by a generator at a power company, and is transformed along the way to a useful voltage to power electrical equipment.

This AC waveform is measured in cycle (or Hertz). One AC waveform as shown is a cycle. 60 of these cycle occur in 1 second, which is called 60 hertz.

The waveform can be also looked at in respect to degrees within the waveform. A full cycle takes is done in 360 degrees.

This waveform would also be called single phase. This is the power found on outlets and lighting circuits.

# Single-phase Power

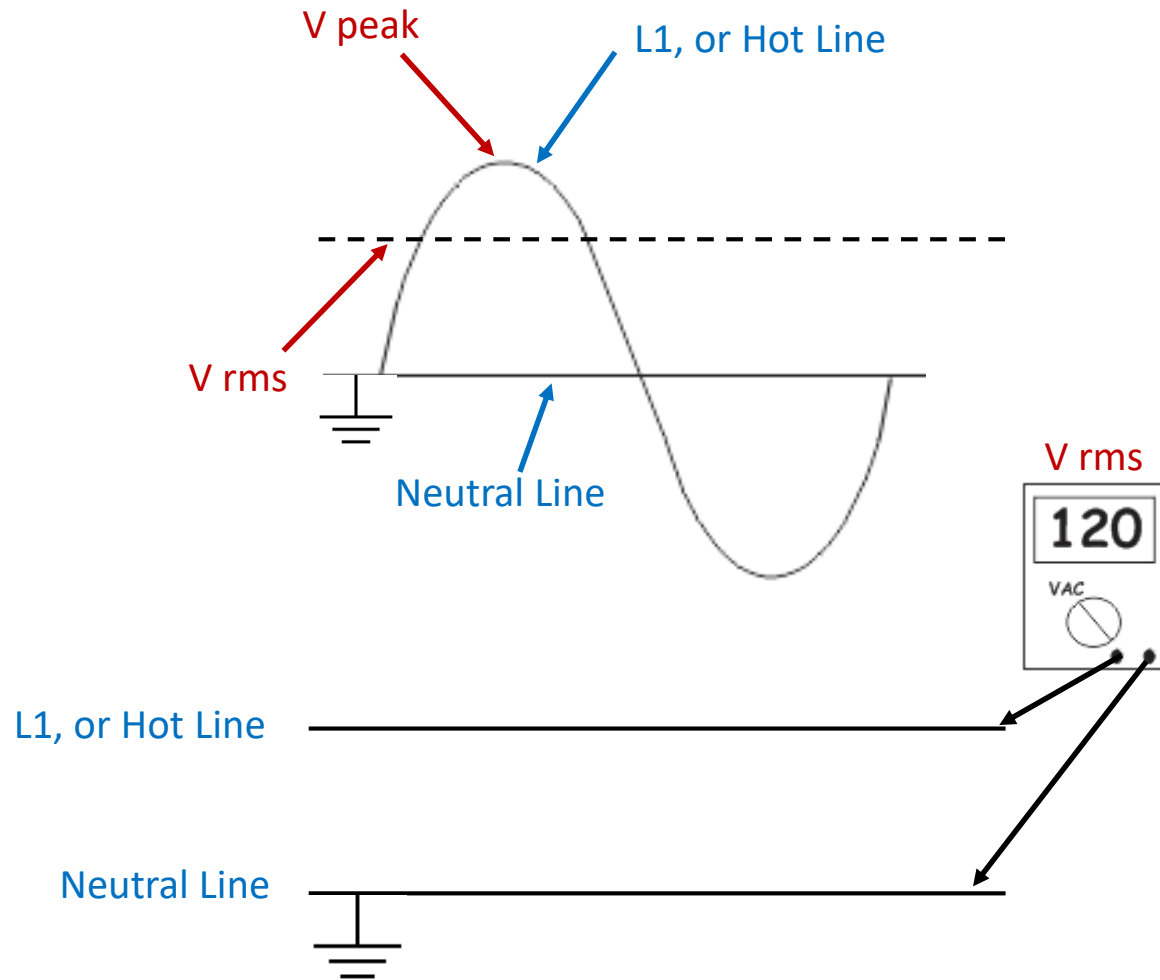

This AC sine wave is the same as single phase power. Notice that when the sine wave is at its highest point on the waveform, it is called the peak, or  $V_{peak}$ . Below it is a dashed line. This is the  $V_{rms}$  (rms stands for Root Mean Squared).

It is important to understand that RMS is what is measured with a DMM. In this example, the voltage measured between the hot and neutral wire is 120Vrms. This is the voltage on the standard 120V outlets found in your home.

It will be important to know how to convert between these two voltage points:

$$V_{peak} = V_{rms} \times 1.414$$

$$V_{rms} = V_{peak} \times 0.707$$

The neutral wire has the equipment ground symbol connected to it. A neutral is a conductor that carries current in normal circuit operations, but it is at ground potential. A neutral wire is identified with a white insulation, when used in a control panel or in a residential application.

# Single Phase (Edison System)

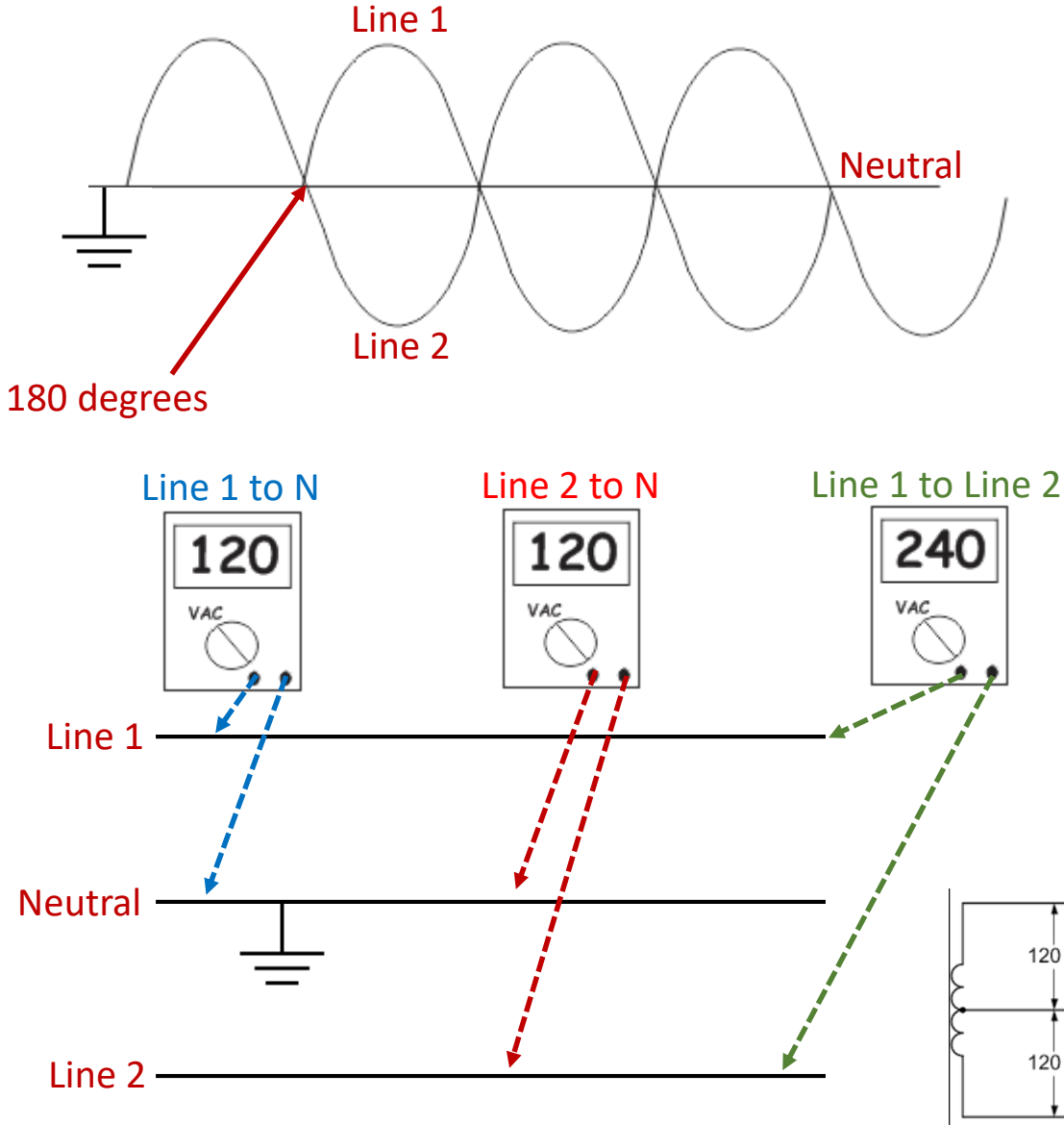

A common single phase power configuration is the 120V/240V 3-wire system, or sometimes referred to as the Edison system (by old-school Electricians).

This type of system is what is used as the power system for a home. It is also used quite extensively in an industrial environment.

There are two hot lines (Line 1 and Line 2). There is also a neutral. There is 180 degree phase shift between the two hot lines.

More characteristics will be discussed on this type of systems when single phase transformers are discussed.

# Single Phase (Edison System)

This graphic shows a standard 120/240V single phase electrical panel. This would be the type of electrical installation in a home or in an industrial environment.

Notice the two hot lines that are connected to the main breaker. Also notice the neutral bar (white wire). This is a residential installation, since the wire used is romax cable. This is evident with the bare grounding wires.

In an industrial installation, romax would not be used. In an industrial installation the grounding wires would have a green insulation on them.

From Line 1 to Line 2, the voltmeter will read 240VAC. From either Line 1 or Line 2, to neutral, the voltmeter will read 120VAC.

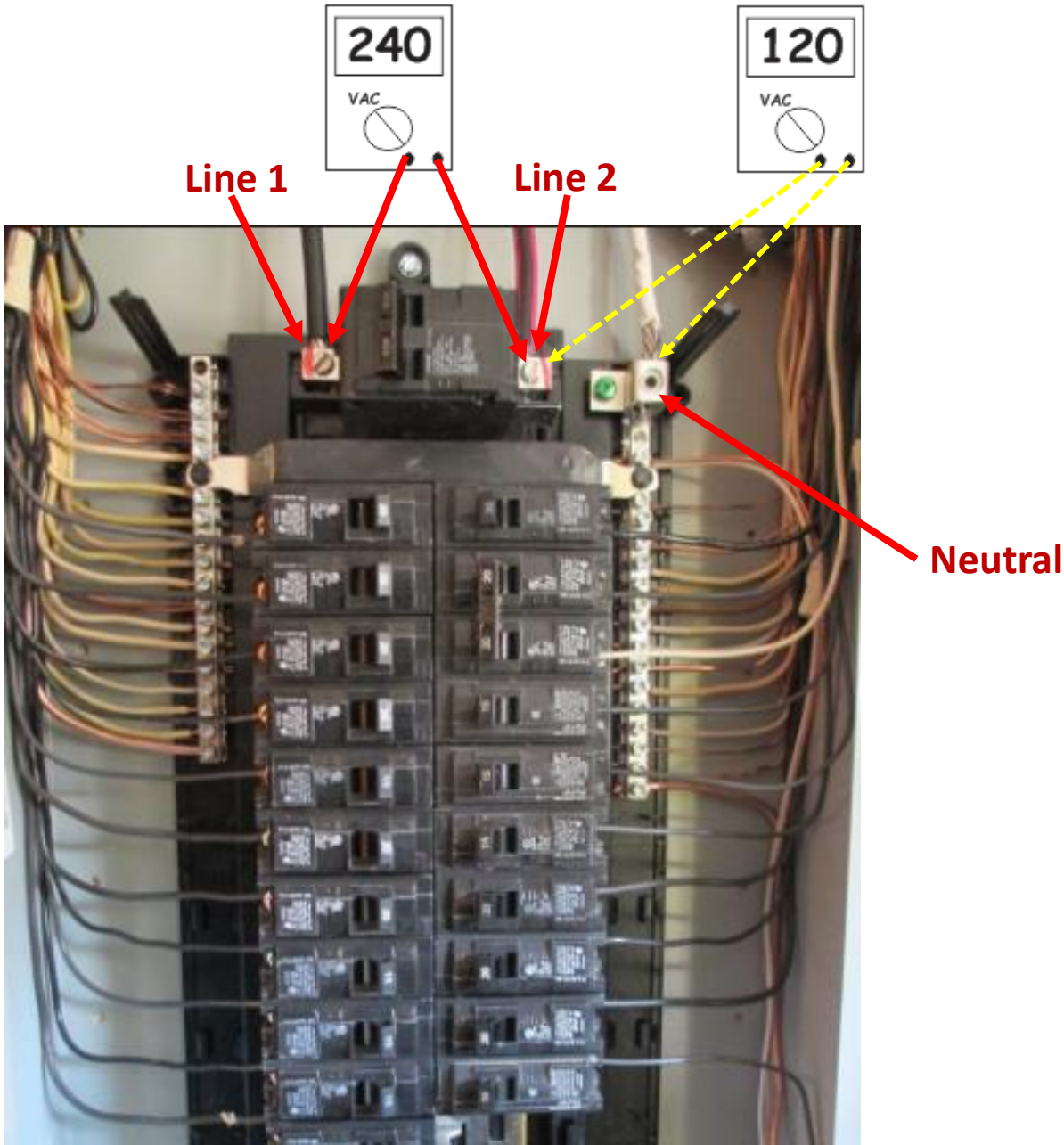

# Three Phase Power

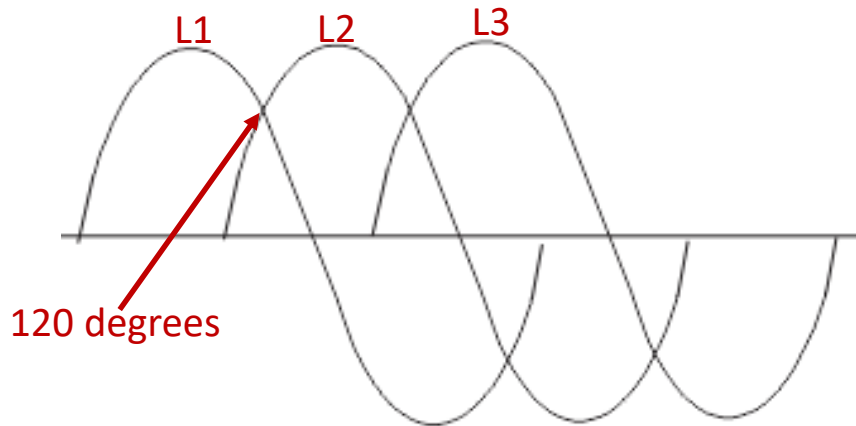

A three phase power waveform would look like this graphic. Notice that this is made up of three single phase waveforms. There is a 120 degrees phase shift with three phase. This means that 120 degrees into the first sine wave, the next single phase sine wave starts. Then 120 degrees later, the next sine wave starts.

Three phase is more powerful than single phase. This is why most industrial motors are three phase. The three phase motors are smaller than the same horsepower single phase motor.

This example is a 240V, three phase system. L1, L2 and L3 are the three power lines. This is a delta voltage (will be explained later), but the most important thing to remember is that there is 240Vrms measured between any two wires.

240V three phase is a common motor voltage.

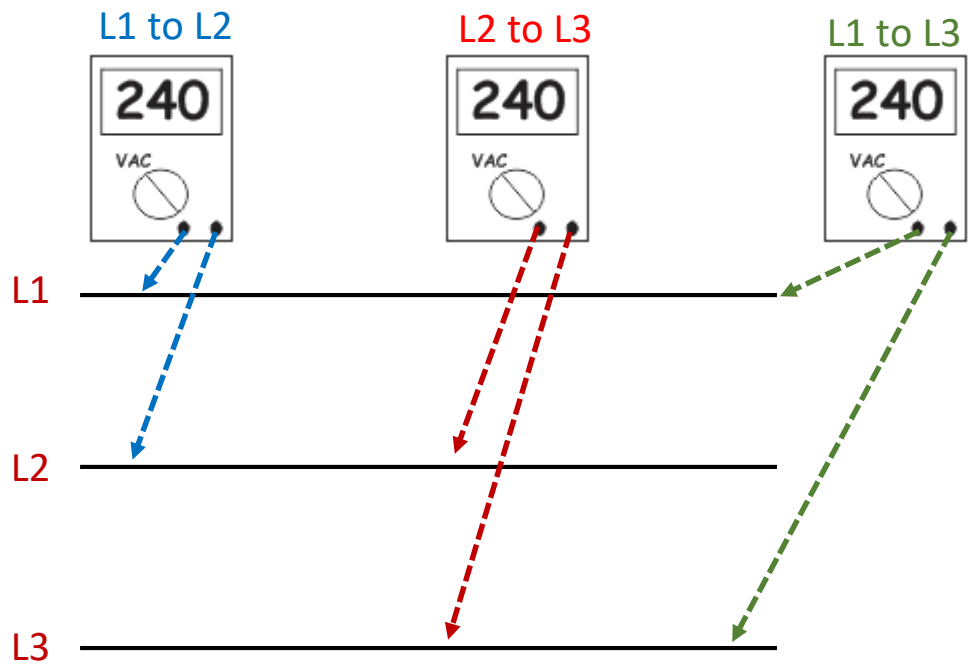

# Three-phase Electrical Panel

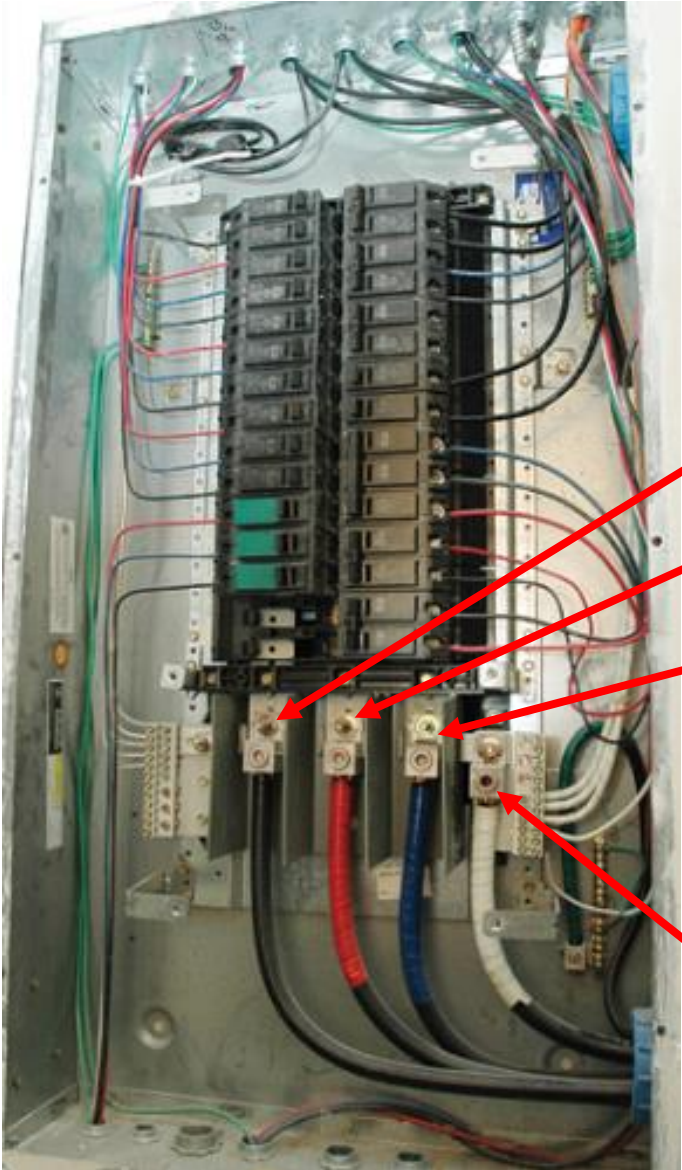

L1

L2

L3

Neutral

This graphic shows a standard three phase electrical panel. This would be the type of electrical installation in an industrial environment.

Notice the three hot lines that are connected to the three lugs in the panel (black, red & blue tape). Also notice the neutral bar (white wire).



# Three phase power configurations

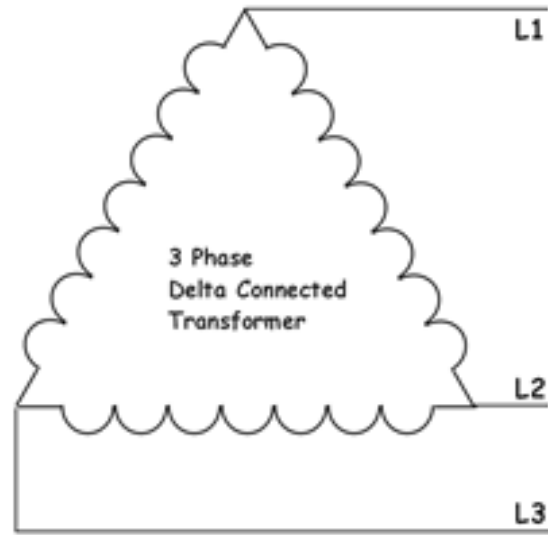
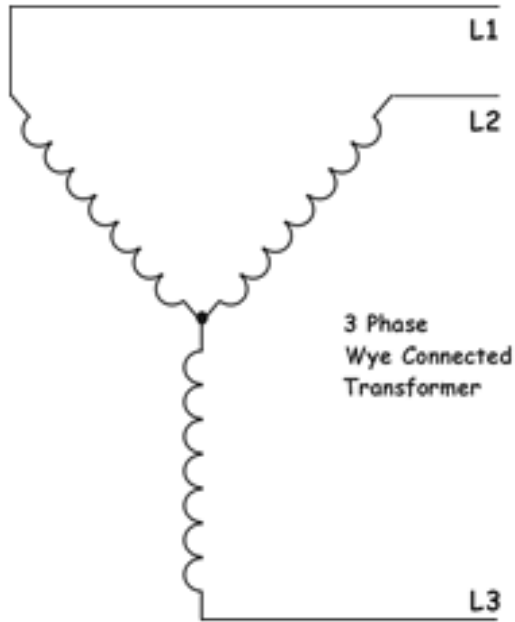

The two configurations for three phase power (primarily the configuration of the transformer windings) is Wye and Delta.

The left graphic is a Wye, and the right graphic is a Delta. These will be discussed more in depth in the following graphics.

The common 3 phase voltages used in industry are:

208 V three phase (a Wye voltage)

240 V three phase (a Delta voltage)

480 V three phase (a Wye voltage)

# More on 3-Phase configurations

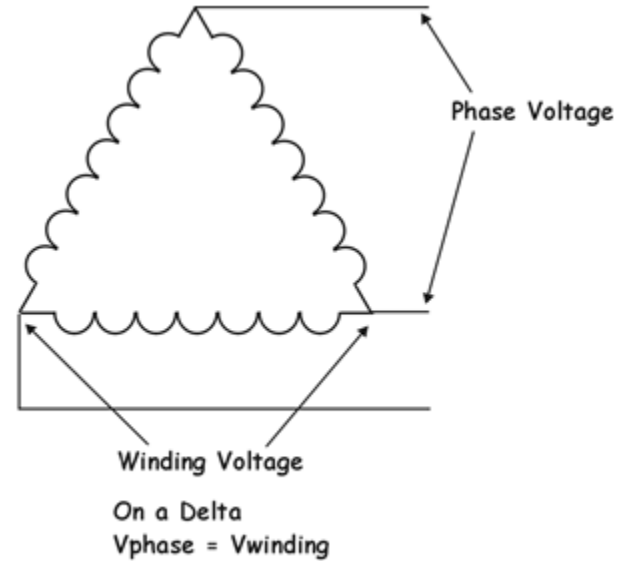
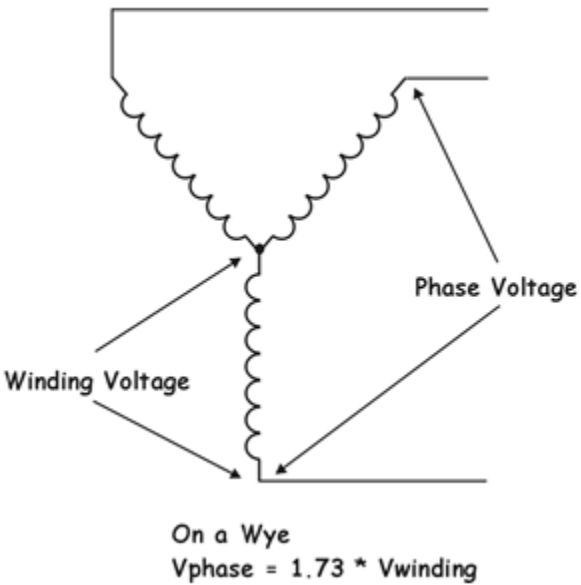

It is important to understand the difference between the phase voltage, and the winding voltage. The graphic will show both of these on both the Wye and Delta configuration.

On a Delta configuration, the Phase voltage and the Winding voltage are the same.  
 $V_{\text{phase}} = V_{\text{winding}}$

On a Wye system, the  $V_{\text{phase}} = 1.73 * V_{\text{winding}}$ .  
1.73 is the square root of three.

# 4-Wire & 5-Wire 3 Phase

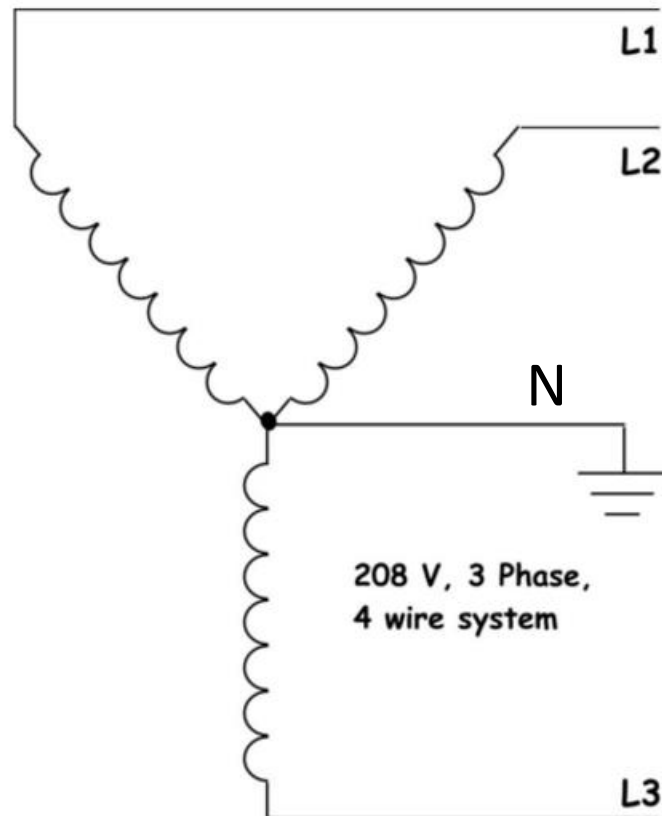

This graphic shows a Wye system with the star point grounded, which creates a neutral wire. A neutral is a wire that carries current in normal circuit operation, and is at ground potential. This is different than a green (equipment ground) wire that carries current only in a fault or short-circuit condition.

This system has 4 wires for normal circuit operation (L1, L2, L3 & N). There is also a green wire (equipment ground) that would be ran in the conduit. Thus the term 208V, three phase, 5-wire system. Years ago, people did not count the green wire in this and termed it a 4-wire system. Modern day, it is a 5-wire system.

# 5-Wire, 3Ph Plug

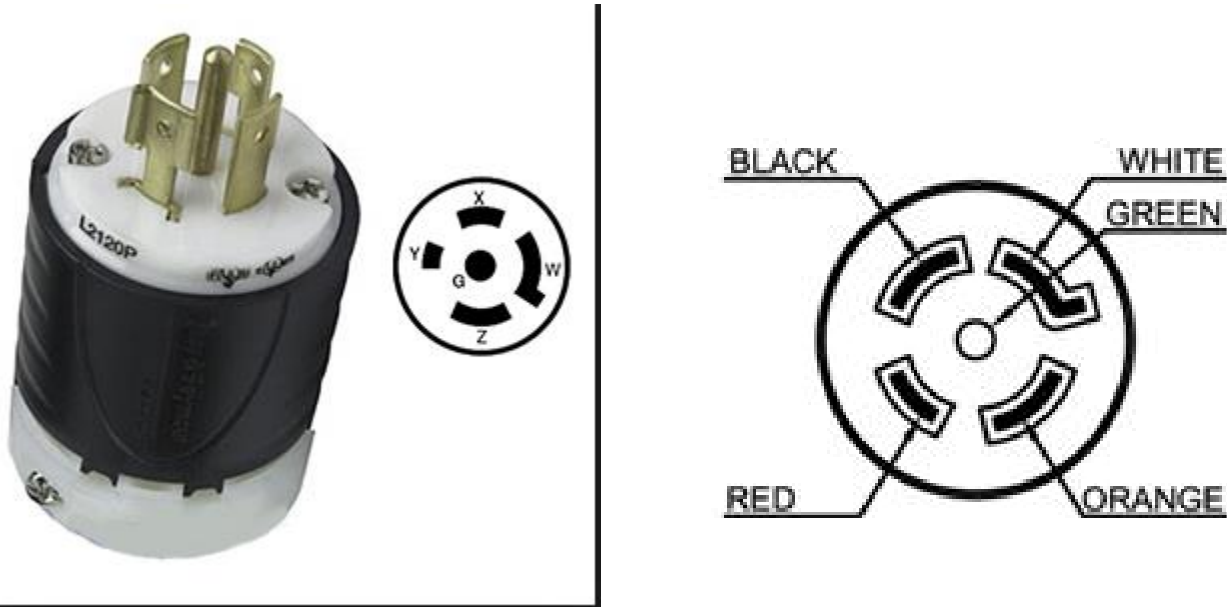

This graphic shows a three phase, 5-wire plug. Many times a user will need to wire a plug, either for a new installation or plug replacement. It is important to know what wires will connect to what terminal.

Notice that the center terminal is the green wire. The larger outer plug piece is the white wire, and the other three will be for L1, L2 & L3. The Black, Red and Orange wire is a common color pattern found in 3 phase cords.



# 4-Wire, 3Ph Plugs

## 3-Pole, 4-Wire Grounding: 3Ø 250V

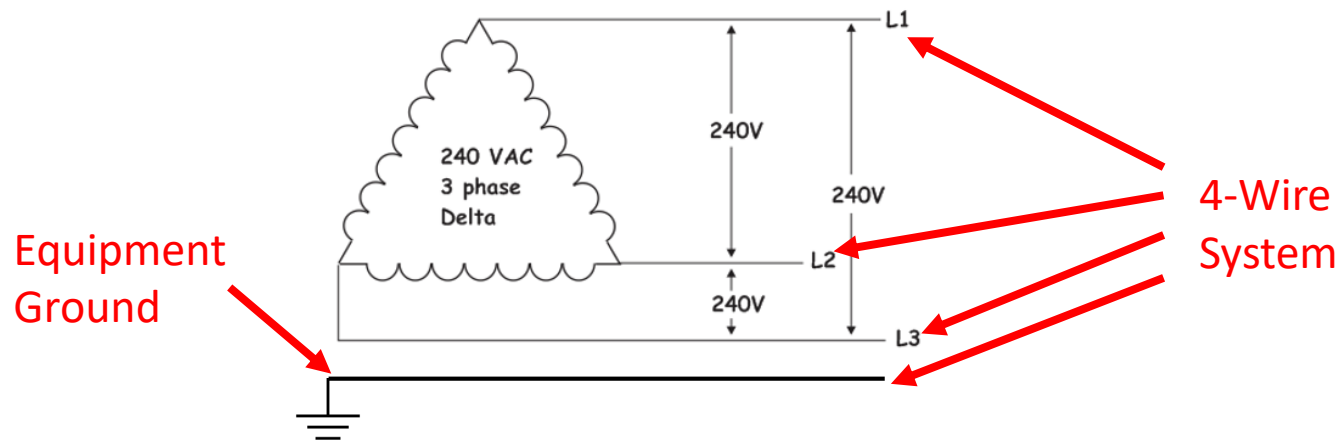
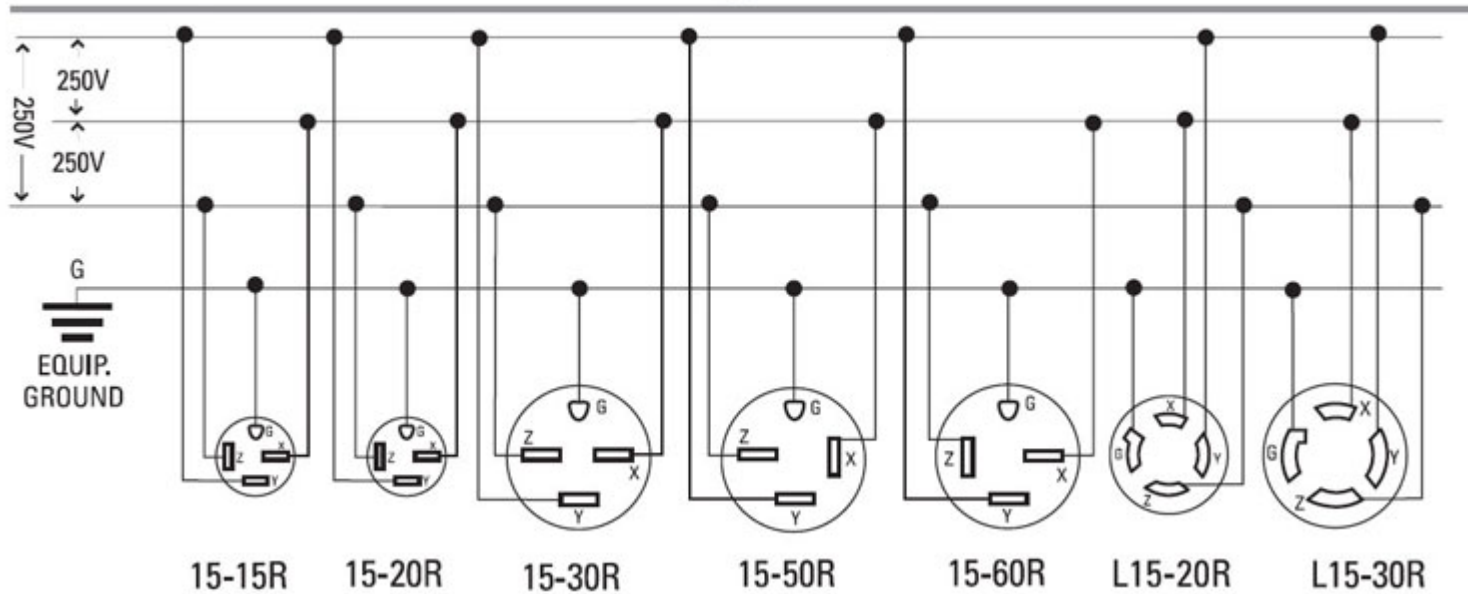

This graphic shows information from a plug manufacturer's cut sheet, illustrating how their 4-wire plugs are connected to a 4-wire system, which would typically be a delta system with an equipment ground.

# GFI Outlet Wiring

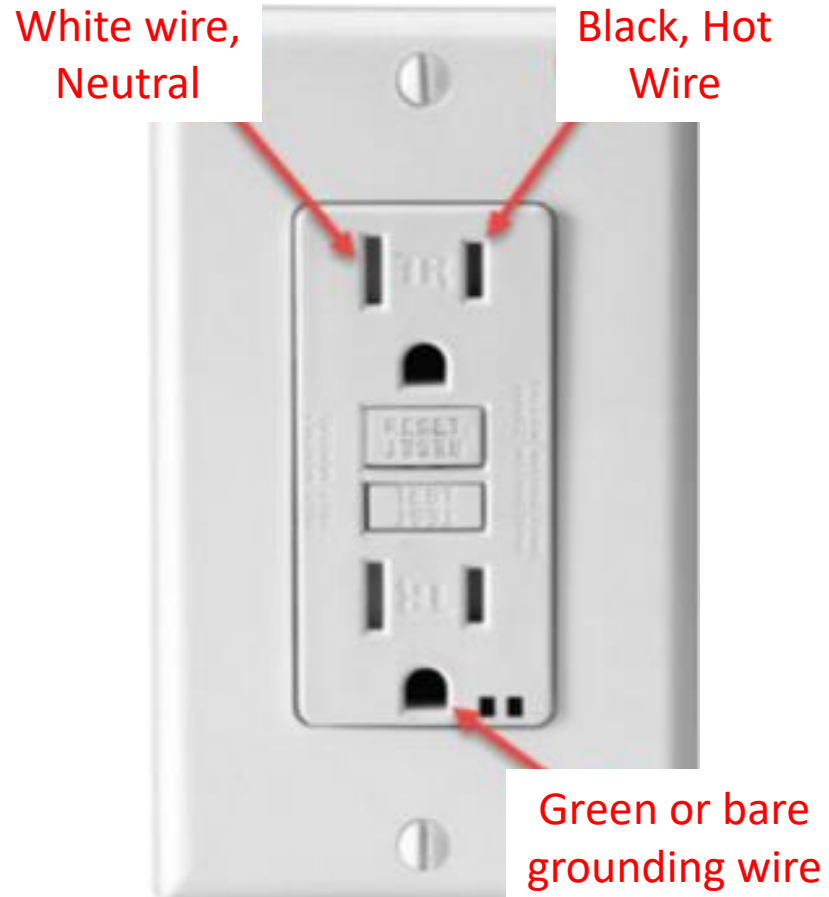

This graphic shows the wiring of a Ground Fault Circuit Interrupter. These devices will be in the form of an outlet, or as a breaker in the power panel. The purpose of these devices is to protect an individual from electrocution by sensing the current difference between the hot and neutral wires. If there is a difference of more than 5mA, the device will trip, shutting off the power. These are required in outside outlets, or in bathrooms; primarily anywhere that there is a lot of moisture.

Notice the wiring is the same as a standard outlet for the hot, neutral and grounding conductor.

These devices will also protect standard outlets that are wired downstream from them.

# Delta 3 phase transformer

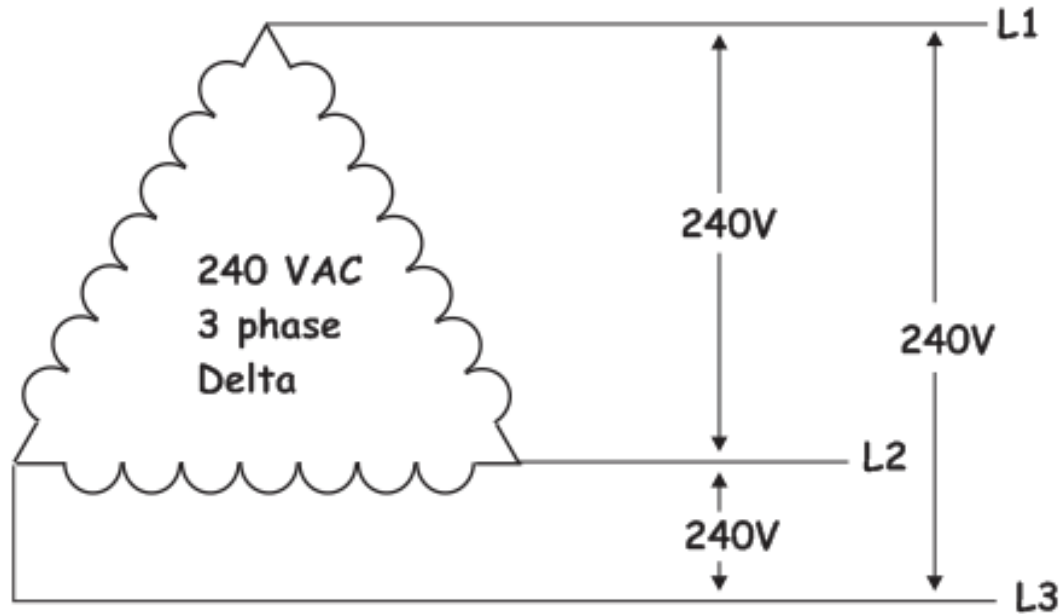

This is a 3 phase, 240V power configuration. The phase voltage and the winding voltage are the same. 240V three phase is a common motor voltage.

Voltages the user would measure:

L1 to L2 = 240V

L2 to L3 = 240V

L1 to L3 = 240V

Years ago these systems would also be configured as a high leg delta system in order to obtain 120VAC. If one of the windings are center tapped, the user could get two 120V circuits. To find out more about the high leg delta system, google "high leg delta systems".

# 3 Phase Wye, 208V 4-wire

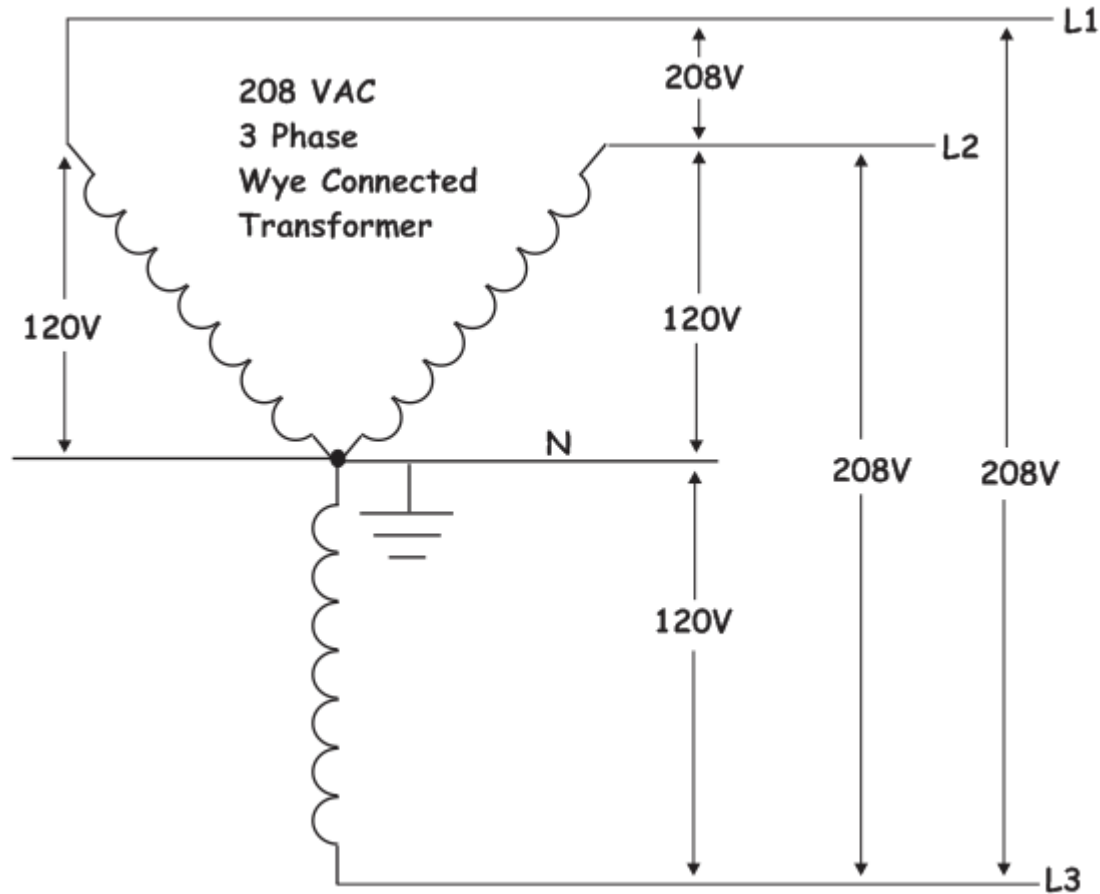

This is a 3 phase 208V 4-wire (some call it 5-wire and count the grounding conductor).

Phase voltage on this system is 208V, and the winding voltage is 120VAC.

To calculate the winding voltage use this formula:

$$V_{\text{winding}} = V_{\text{phase}} / 1.73$$

$$208V / 1.73 = 120VAC$$

To calculate the phase voltage, use this formula:

$$V_{\text{phase}} = V_{\text{winding}} * 1.73$$

$$\text{So: } 120V * 1.73 = 208V$$

Voltages the user would measure:

$$L1 \text{ to } L2 = 208V$$

$$L2 \text{ to } L3 = 208V$$

$$L1 \text{ to } L3 = 208V$$

$$L1 \text{ to } N = 120V$$

$$L2 \text{ to } N = 120V$$

$$L3 \text{ to } N = 120V$$



# 3 Phase Wye, 480V 4-wire

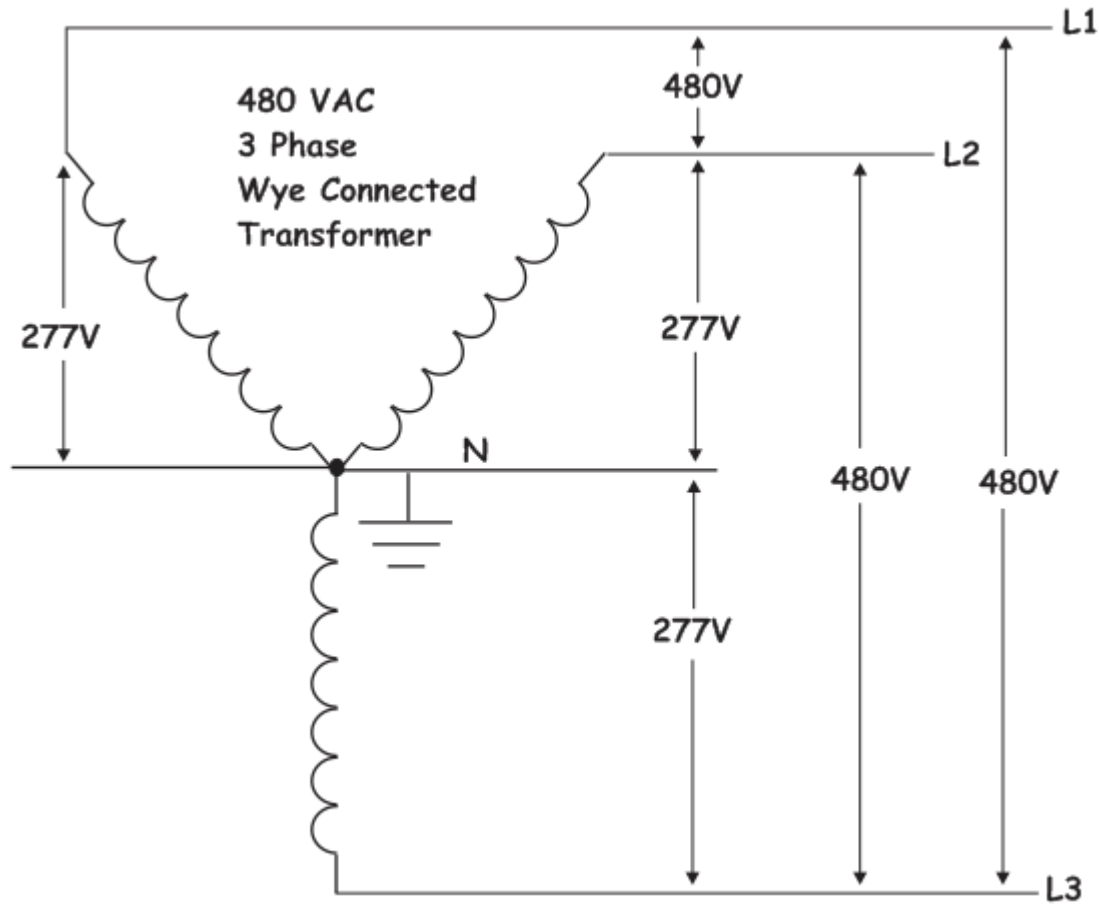

This is a 3 phase 480V 4-wire (some call it 5-wire and count the grounding conductor).

Phase voltage on this system is 480V, and the winding voltage is 277VAC.

To calculate the winding voltage use this formula:

$$V_{\text{winding}} = V_{\text{phase}} / 1.73$$

$$480V / 1.73 = 277VAC$$

To calculate the phase voltage, use this formula:

$$V_{\text{phase}} = V_{\text{winding}} * 1.73$$

$$\text{So: } 277V * 1.73 = 480V$$

Voltages the user would measure:

$$L1 \text{ to } L2 = 480V$$

$$L2 \text{ to } L3 = 480V$$

$$L1 \text{ to } L3 = 480V$$

$$L1 \text{ to } N = 277V$$

$$L2 \text{ to } N = 277V$$

$$L3 \text{ to } N = 277V$$

# Common Industrial Voltages

The following are the common industrial voltages found on bus bars and in load centers in industry:

1. 480V three phase – Used primarily for three phase industrial motors. Single phase 480 V is also used to feed control and power transformers, stepped down to a lower voltage.
2. 240V three phase – Used primarily for three phase industrial motors (480V is best for motor installations, so smaller size wire can be used), but also one a single phase can be used to power heating elements, and 240V single phase motors.
3. 208V three phase – Used to power some three phase motors (480V is best for motor installations, so smaller size wire can be used). 208V 4-wire (termed 5-wire with the grounding conductor) is used for utility panels, to obtain 120V for utility devices (outlets and lighting circuits).
4. 120V/240V single phase – Many small applications: outlets, lighting, heating elements, fractional HP motors, control systems (PLC), etc.
5. 277V single phase – This is the winding voltage (From any hotline: L1, 2, 3, to the Neutral wire) on a 480V 4 wire system.
6. Control System Voltages: The two industry standard industrial control system voltages is 120VAC and 24VDC. 24VDC is the standard for new installations, due to reduced arc-flash concerns. 24VDC will be obtained from a 24VDC power supply found in the control cabinet (usually DIN rail mounted).
7. Lighting Circuit Voltages: 120VAC or 277VAC are used for florescent lighting ballasts. For high intensity lighting, 480VAC or 240VAC single phase is typically used.
8. Loads in Industry: The three most common loads found in industry is motors, heating elements and lighting ballasts. Heating elements are resistive loads, but motors and ballasts are inductive loads.

# Ratings on Electrical Disconnects



Similar Item Shown



Siemens GFC321N Safety Switch 30A, 3P, 240V,

The 600 Volt disconnect is larger in size than a 240 Volt disconnect. 600 volt rated fuses will be longer than 240 volt rated fuses, thus the 600 volt disconnects will be taller, and will have more spacing between the fuses, due the arc potential between the higher voltage lines.

The disconnect has a maximum voltage rating, and a maximum current rating

30 Amp 600VAC Single Throw Safety Switch 3P

SIEMENS | Zoro #: G3078284 | Mfr #: HF361

0.0 Be the first to Write a Review

Product Specifications	
BRAND	Siemens
MANUFACTURER PART NUMBER	GNF321
PRODUCT TYPE	Safety Switches
DUTY TYPE	General Duty
FUSIBLE / NON-FUSIBLE	Non-Fusible
AMPS	30
VOLTAGE	240
POLES	3
WIRES	3
NEUTRAL INCLUDED	No
ENCLOSURE TYPE	1
VIEWING WINDOW	No
WEIGHT	4
CSA CERTIFIED	No



# Practice Question #1

- What is the advantage of wiring a dual voltage, 3 phase motor for the higher voltage (usually 480V)?
  - a. Motors run more efficiently on higher voltage
  - b. Smaller size power wires are required during installation
  - c. Lower voltages make the motors run slower
  - d. Most motors are not dual voltage

# Practice Question #1

- What is the advantage of wiring a dual voltage, 3 phase motor for the higher voltage (usually 480V)?
  - a. Motors run more efficiently on higher voltage
  - b. **Smaller size power wires are required during installation**
  - c. Lower voltages make the motors run slower
  - d. Most motors are not dual voltage

Explanation: Many three phase motors are dual voltage rated, for primarily 240V and 480V. Their full load amps rating will also have two values. If the motor is wired for the lower voltage, the current will be approximately twice what the FLA rating will be for the 480V wiring connections. Thus the wiring for higher voltage would require a smaller gauge wire to feed the motor.

# Practice Question #2

- In the following 208V, three phase system, what will be the winding voltage measured from L2 to N?
  - a. 60 volts
  - b. 120 volts
  - c. 208 volts
  - d. 240 volts

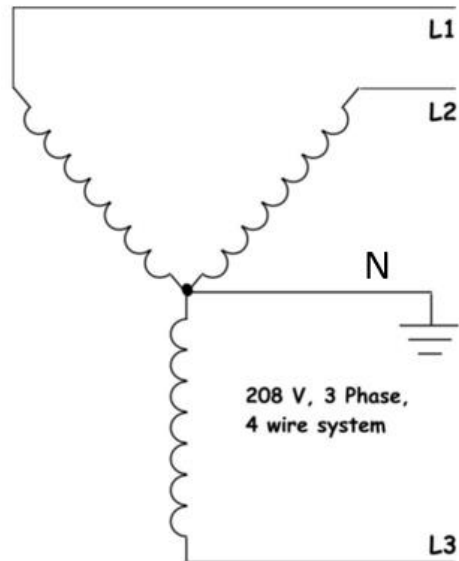

# Answer to Practice Question #2

- In the following 208V, three phase system, what will be the winding voltage measured from L2 to N?
  - a. 60 volts
  - b. **120 volts**
  - c. 208 volts
  - d. 240 volts

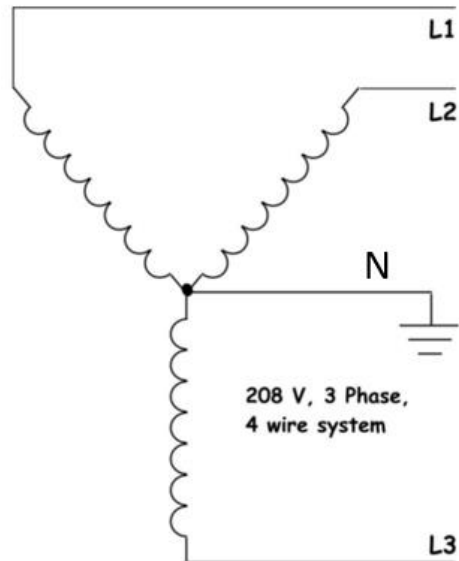

Explanation: The correct answer is b., 120 volts.  
 $V_{\text{winding}} = V_{\text{phase}}/1.73$

$$208\text{V}/1.73 = 120\text{V}$$

# Practice Question #3

- On the following three phase plug, which terminal would the White wire (neutral) connect to for a 208V, 5-wire feed.
  - a. A
  - b. B
  - c. C
  - d. D
  - e. E

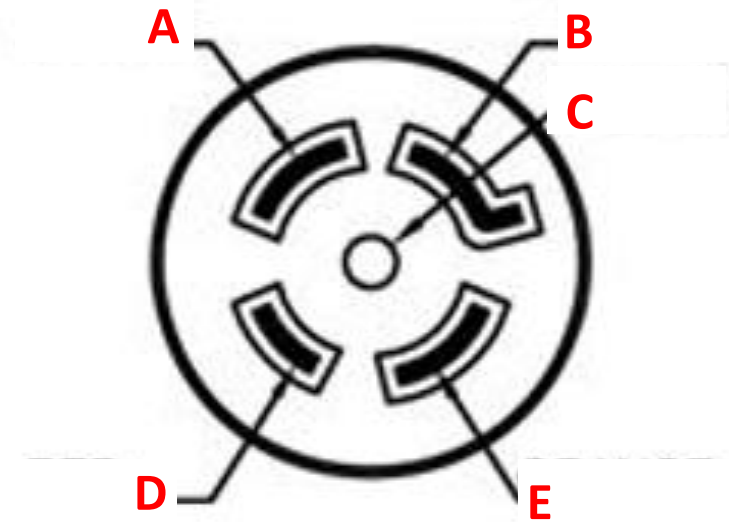



# Practice Question #3

- On the following three phase plug, which terminal would the White wire (neutral) connect to for a 208V, 5-wire feed.
  - a. A
  - b. **B**
  - c. C
  - d. D
  - e. E

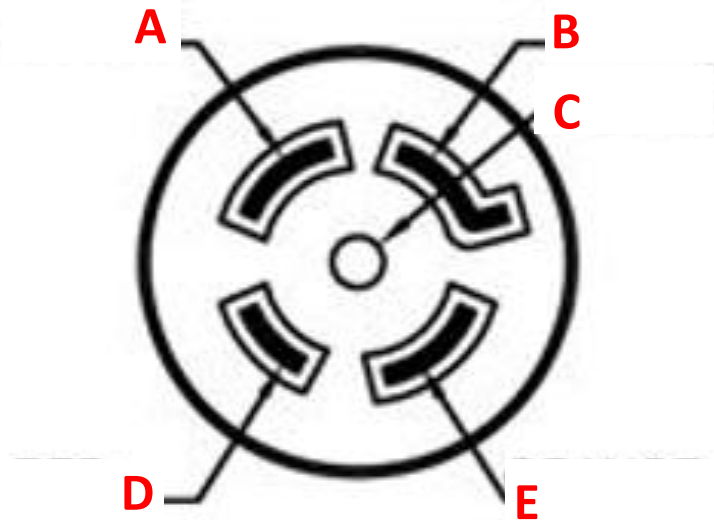

The correct answer is B. See the original color diagram on the right. The center post is always the green wire.

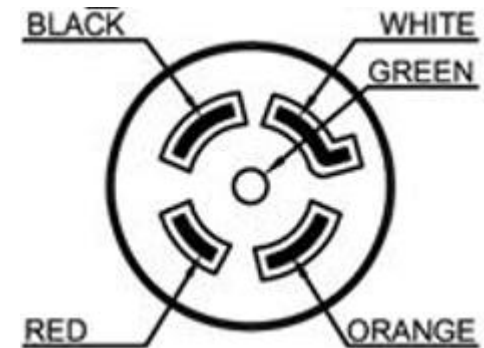

# This Concludes this Instructional Document

## **DOL DISCLAIMER:**

This product was funded by a grant awarded by the U.S. Department of Labor's Employment and Training Administration. The product was created by the grantee and does not necessarily reflect the official position of the U.S. Department of Labor. The Department of Labor makes no guarantees, warranties, or assurances of any kind, express or implied, with respect to such information, including any information on linked sites and including, but not limited to, accuracy of the information or its completeness, timeliness, usefulness, adequacy, continued availability, or ownership.



This work is licensed under a [Creative Commons Attribution 4.0 International License](https://creativecommons.org/licenses/by/4.0/).